

CTB

- Zone 1, 2, 21, 22
- Electropolished 316 L stainless steel junction boxes
- 23 sizes and 6 different depths
- Gasket resistant to acids and high temperatures
- IK10 mechanical strength
- IP66

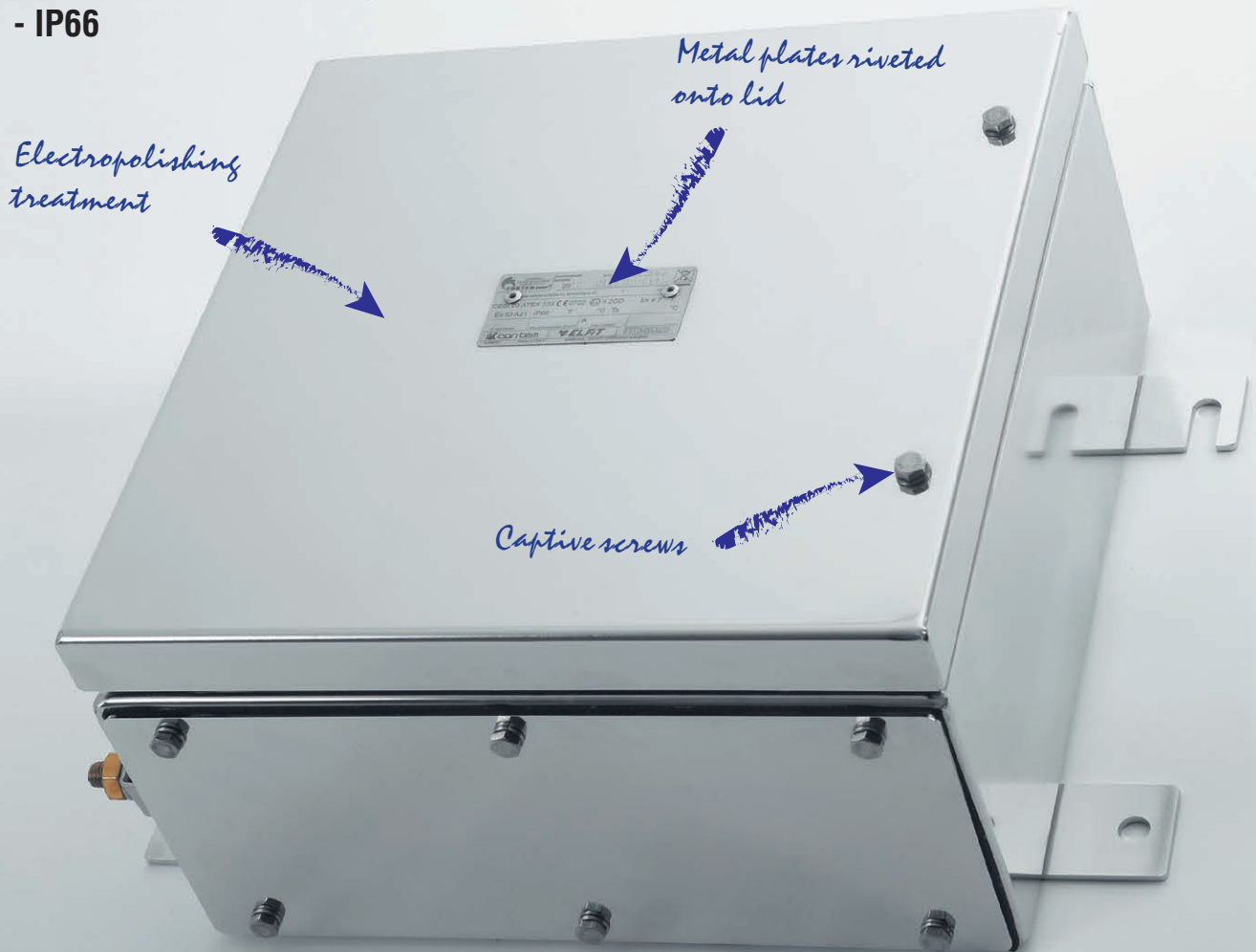

ORIGINAL PRODUCT



Detail of TIG welding
of walls



Earth stud with cable anti-rotation bracket



Hinges detail

CTB series junction boxes: criteria for choosing the right product

When it comes to deciding on an increased safety enclosure, there is a whole series of essential data to be taken into account if you are to make the right choice: the mechanical strength of the materials, corrosion resistance, the IP protection rating and IK impact protection rating in the case of enclosures for watertight/ industrial use.

Mechanical strength

Properties	Unit	Stainless steel	Aluminium	Polyester
Density	g/cm ³	8.0	2.65	1.7
Tensile strength	MPa	500-700	80-110	130
Elongation	%	60-40	4-10	2
Modulus of elasticity	GPa	193	79	11
Yield strength	MPa	≥ 200	80-165	-
Coeff. of thermal expansion (20-100°C)	10 ⁻⁶ K ⁻¹	16	21	-
Resistivity	Ωm	7.5x10 ⁻⁷	4.8x10 ⁻⁸	-
Electrical conductivity	Ω ⁻¹ m ⁻¹	1.33x10 ⁶	2.08x10 ⁷	-

The graph below gives an overview of what use the various materials are suitable for based on the mechanical stress and harshness of the environmental conditions likely to be encountered.

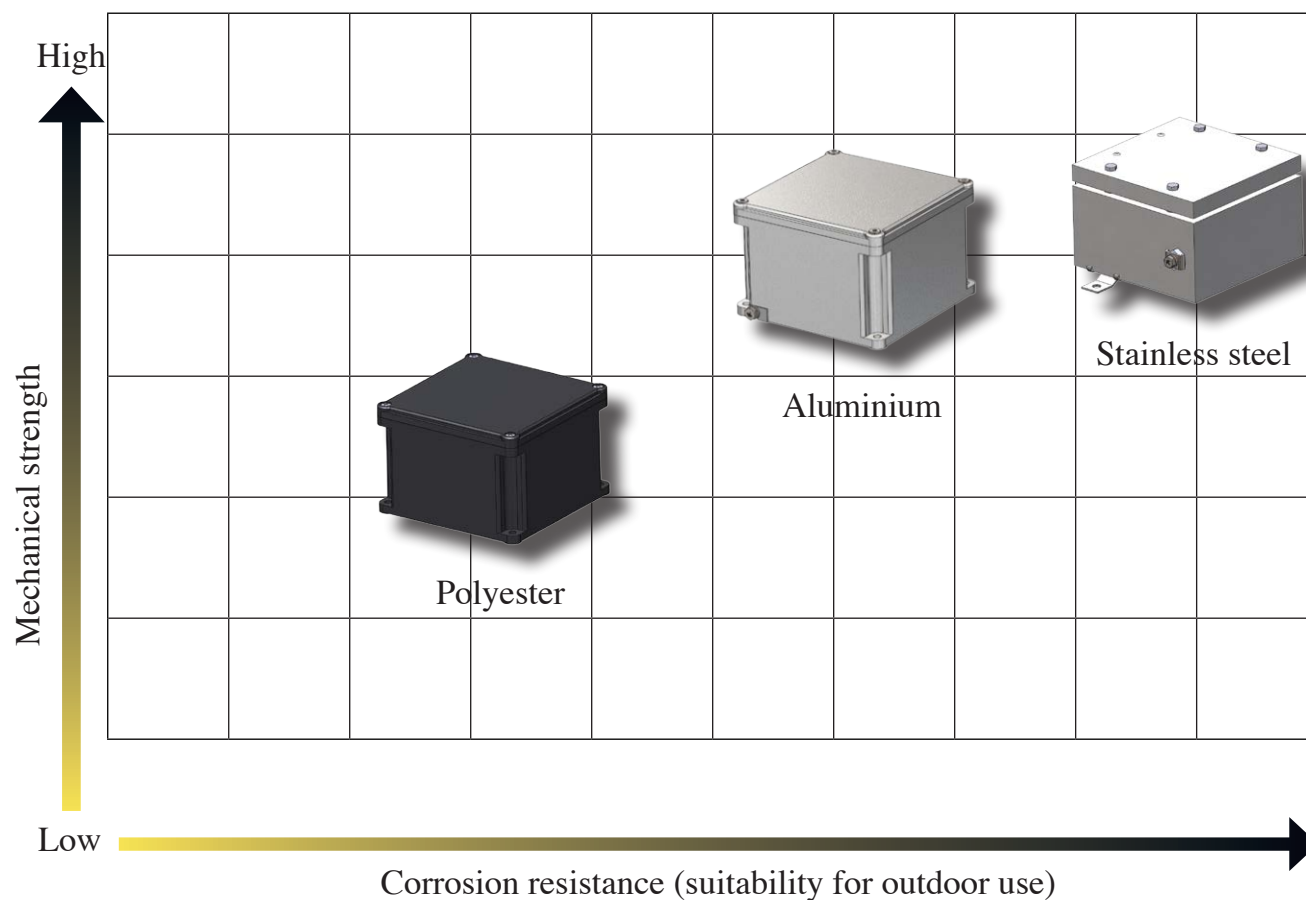

IP PROTECTION RATINGS (IEC 529, EN 60529-4, CEI 70-1 ed. 11/92)

The table gives protection ratings in accordance with standard CEI 70-1 ed. 11/92. Ratings are identified by the acronym IP followed by 2 digits, to which 2 letters may be added, indicating the degree to which persons are protected against access or other properties. There is some variation in the application of ratings 7 and 8 relating to the ingress of liquids, with these ratings not always meaning that the item is suitable for lower levels (whereas IP rating x4 also covers the lower levels).

IMPACT PROTECTION RATINGS

This classification shows the acceptable level of strength, when evaluating a product's safety, and is mainly employed in relation to testing on electromechanical products.

1ST DIGIT PROTECTION AGAINST SOLID OBJECTS		2ND DIGIT PROTECTION AGAINST MOISTURE		PROTECTION AGAINST EXTERNAL MECHANICAL IMPACT *	
0	Not protected	0	Not protected	IK00	Not protected
1	Protected against solid objects greater than 50mm in Ø	1	Protected against vertically falling drops of water	IK01	0.25 kg 5.6 cm Protected against impact energy of 0.15J
2	Protected against solid objects greater than 12mm in Ø	2	Protected against rain when tilted up to 15°	IK03	0.25 kg 14 cm Protected against impact energy of 0.35J
3	Protected against solid objects greater than 2.5mm in Ø	3	Protected against rain when tilted up to 60°	IK05	0.25 kg 28 cm Protected against impact energy of 0.7J
4	Protected against solid objects greater than 1mm in Ø	4	Protected against splashing water	IK06	0.25 kg 40 cm Protected against impact energy of 1J
5	Protected against dust	5	Protected against jets of water from all directions	IK07	0.5 kg 40 cm Protected against impact energy of 2J
6	Totally protected against the ingress of dust	6	Protected against heavy seas	IK08	1.7 kg 30 cm Protected against impact energy of 5J
ADDITIONAL LETTER**		7	Protected against the effects of immersion	IK09	5 kg 20 cm Protected against impact energy of 10J
A	Protected against access with the back of the hand	8	Protected against the effects of continuous immersion	IK10	5 kg 40 cm Protected against impact energy of 20J
B	Protected against access with a finger				
C	Protected against access with a tool				
D	Protected against access with a wire				
OPTIONAL LETTER					
H	High-voltage device				
M	Tested against the harmful effects of water ingress with the equipment running				
S	Tested against the harmful effects of water ingress with the equipment not running				
W	Suitable for use in specified atmospheric conditions				

* As per IEC EN 50102: 1996-05; IEC EN 60078-2-7-5: 1998-09.

** Optional letter describing protection against access by persons. Only used if protection against access to hazardous parts is greater than that indicated by the first digit, or if only protection against access to hazardous parts is given and an X is used in place of the first digit.

CTB... series (Ex e) and (Ex i) stainless steel junction boxes

CTB, CSTB junction box series is made from AISI 316L stainless steel sheet to ensure correct service in the aggressive environments it is installed in. With their high standard of quality and use of select raw materials processed with cutting-edge technologies, these boxes successfully withstand harsh external factors, such as water, dust, hard knocks, vibrations, corrosion and extreme fluctuations in temperature, ensuring a very long period of consistently reliable service. CTB, CSTB series enclosures are usually installed in industrial plants where there is a risk of explosion and fire, classified as Zone 1, 2, 21, 22; they are mainly used as junction boxes or for routing cables for analogue or digital signals and for control and monitoring associated with equipment such as motors, pumps...etc.. The enclosures' main purpose is to protect the components inside from external factors, such as moisture or dust, which means they must have a suitable IP rating. Cortem tests its enclosures according to standard EN 60529 in its own accredited laboratory to provide assurance that this requirement is met. Cortem works alongside customers as a reliable partner, configuring custom solutions tailored to their individual requirements and offering an extensive range of ideal products and components that are configured to produce cost-effective bespoke solutions.

Cortem Group labels its products with a non-removable adhesive label measuring 2 cm in diameter featuring a hologram with the inscription "TESTED ORIGINAL PRODUCT". It's complete with an alphanumeric code, as a safety measure against the illegal sale of imitations and fakes so that all the products are guaranteed as original. Non-compliance with the International standards entails serious risks for the environment, especially for those working daily on the plants.

TYPE AND APPLICATION

Choosing an appropriate container is a key step in the project development process, making it essential to approach the decision systematically, evaluating all variables methodically: where our equipment is being installed, the environmental conditions on site, what degree of protection it must have, what space is available and how it is due to be set up. Once you have processed all this information, you should be able to determine which product best suits the design requirements in question.

ENVIRONMENTAL CONDITIONS

The first factor to consider is what environmental conditions the equipment is going to be installed in, whether it will be indoors or outside, and what environments it is required to operate in: pharmaceutical, chemical, petrochemical, food, shipbuilding, agricultural industries...

DIMENSIONS

The size of the space available for inserting the enclosure and its components must be determined early on in the process.

DESIGN

Taking into account the technical aspect, product design and appearance is also important in ensuring the equipment to be installed in the enclosure is integrated seamlessly. A Cortem team of experts is on hand every day to address your questions and come up with the best solutions.

Cortem enclosures have passed:

- IP protection testing;
- IK strength testing;
- vibration and impact resistance testing;
- salt mist testing for corrosion resistance;
- heat resistance testing;
- low temperature resistance testing.



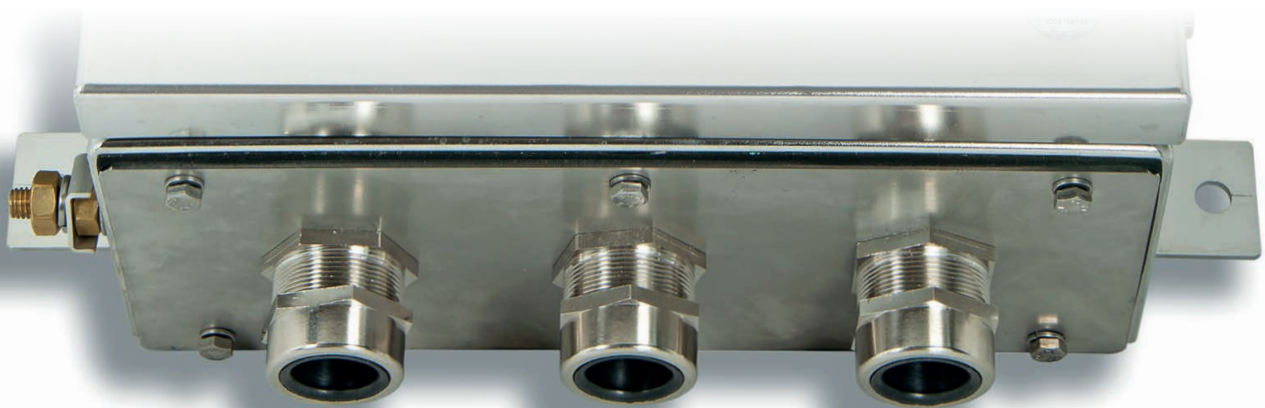
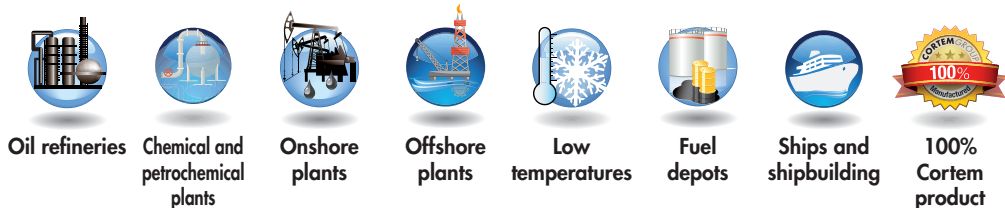



Application sectors:



CTB... series (Ex e) and (Ex i) stainless steel junction boxes

Ex e

CERTIFICATION DATA FOR ENCLOSURES WITH TERMINALS







Classification:	Group II	Category 2GD		
Installation: EN 60079.14	zone 1 - zone 2 (Gas)	zone 21 - zone 22 (Dust)		
Marking:	CE 0722  II 2GD Ex e IIC T.. Gb - Ex tb IIIC T.. Db IP66			
	CE 0722  II 2GD Ex ia IIC T.. Gb - Ex ia IIIC T.. Db IP66			
	CE 0722  II 2GD Ex e ia IIC T.. Gb - Ex tb ia IIIC T.. Db IP66			
Certification:	ATEX	CESI 03 ATEX 333		
	IEC Ex	CES 13.0001	All IEC Ex certification data can be downloaded from www.cortemgroup.com	
	GOST R	AVAILABLE	All GOST R certification data can be downloaded from www.cortemgroup.com	
Standards:	CENELEC EN 60079-0: 2012, EN 60079-7: 2007, EN 60079-11: 2012, EN 60079-31: 2009, EN 60079: 1991 and EUROPEAN DIRECTIVE 94/9/EC: 1994 IEC 60079-0: 2011, IEC 60079-7: 2006, IEC 60079-11: 2011, IEC 60079-31: 2008			
 Ambient Temp.:	 See "ambient temperature range" table 			
Degree of protection:	IP66			

STANDARD AMBIENT TEMPERATURE RANGE FOR ENCLOSURES WITH TERMINALS

AMBIENT TEMPERATURE	TEMPERATURE CLASS	MAXIMUM SURFACE TEMPERATURE	MAXIMUM TERMINAL OPERATING TEMPERATURE
-40°C +40°C	T6	T85°C	+80°C
-40°C +55°C	T5	T100°C	+100°C

Warning: please contact our sales department for other permissible ambient temperature ranges.

CERTIFICATION DATA OF ENCLOSURES FOR CONTROL, MONITORING AND SIGNALLING UNITS

Classification: 94/9/EC	Group II	Category 2GD		
Installation: EN 60079.14	zone 1 - zone 2 (Gas)	zone 21 - zone 22 (Dust)		
Marking:	CE 0722  II2GD - Ex de IIC T6/T5 Gb - Ex tb IIIC T85°C/T100°C Db - IP66			
Certification:	ATEX	CESI 03 ATEX 115		
	IEC Ex	CES 11.0032	All IEC Ex certification data can be downloaded from www.cortemgroup.com	
	GOST R	AVAILABLE	All GOST R certification data can be downloaded from www.cortemgroup.com	
Standards:	CENELEC EN 60079-0: 2012, EN 60079-7: 2007, EN 60079-11: 2012, EN 60079-31: 2009, EN 60529: 1991 and EUROPEAN DIRECTIVE 94/9/EC: 1994 IEC 60079-0: 2011-06, IEC 60079-7: 2006-07, IEC 60079-11: 2008-11, IEC 60529: 2001			
 Ambient Temp.:	 -40°C +40°C 		With temperature class T6 and maximum surface temperature T85°C.	
	 -40°C +55°C 		With temperature class T5 and maximum surface temperature T100°C.	
Degree of protection:	IP66			

CTB... series (Ex e) and (Ex i) stainless steel junction boxes

EXPLODED VIEW OF ACCESSORIZED CTB ENCLOSURE

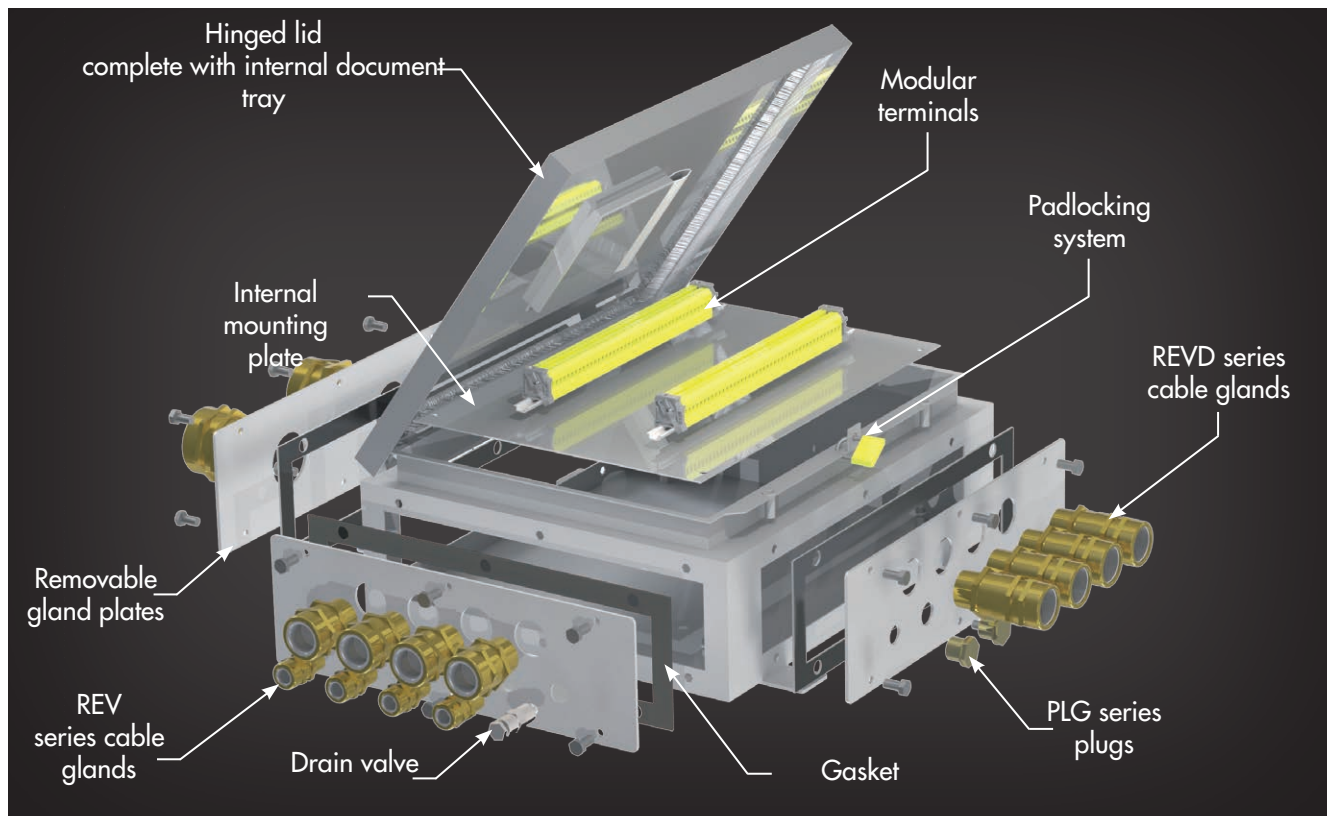

MECHANICAL FEATURES

Body and lid:	AISI 316L stainless steel
Hinges:	Stainless steel AISI316L (included on CTB series, non included on CSTB series)
Impact protection rating:	IK10
Gasket:	Resistant to acids, hydrocarbons and high temperatures, located between body and lid. Ensures consistent protection to IP66 during use
Certification label:	Stainless steel plate riveted onto lid
Bolts and screws:	Stainless steel captive variety
Earth screws:	Stainless steel. On inside and outside of body complete with anti-rotation brackets
Mounting:	Welded AISI 316L stainless steel feet

ACCESSORIES AVAILABLE ON REQUEST/ SPECIAL REQUESTS

- Internal anti-condensation coating RAL 2004 (pure orange)
 - External epoxy coating in different colour (specify the RAL number)
 - Breather valve Code ECD-210S; Drain valve Code ECD-210S
 - Internal mounting plate: stainless steel (code B...-443)
 - Terminal block mounting rails (code OBO2060/S)
 - Padlocking system
 - Padlock (code VIRO552)
 - ATEX-CERTIFIED TERMINALS: terminals must be chosen from the list of approved manufacturers: Cabur, Phoenix, ABB, Entrelec, Wago, Weidmuller. When supplied as an Ex i enclosure (for low-voltage instruments), it comes with suitably identified blue terminals.
 - DIN rail.
 - Hole options: through holes with no threading
- Only use cable glands that meet ATEX, IECEx directive requirements. Use gaskets and lock nuts on entries to ensure IP66 protection.**

CTB... series (Ex e) and (Ex i) stainless steel junction boxes

Ex e

ENCLOSURE SELECTION CHART

Code	Outside dimensions			Inside dimensions			Mounting		Weight kg
	A	B	C	E	F	c	a1	b1	
CSTB121208	120	120	80	84	60	26	-	145	
CSTB151509	150	150	90	114	90	36	-	175	
CSTB191910	190	190	100	154	130	46	-	215	
CTB221513	229	152	130	169	92	75	152	208	
CTB262616	260	260	160	224	200	100	170	316	
CTB262620	260	260	205	224	200	145	170	316	
CTB303016	306	306	160	270	246	100	203	361	
CTB303020	306	306	205	270	246	145	203	361	
CTB382616	380	260	160	344	200	100	250	316	
CTB382620	380	260	205	344	200	145	250	316	
CTB453816	450	380	160	414	322	100	305	437	
CTB453820	450	380	205	414	322	145	305	437	
CTB484816	480	480	160	444	420	100	327	535	
CTB484820	480	480	205	444	420	145	327	535	
CTB503516	500	350	160	464	290	100	350	406	
CTB503520	500	350	205	464	290	145	350	406	
CTB624516	620	450	160	584	390	100	450	506	
CTB624520	620	450	205	584	390	145	450	506	
CTB745520	740	550	205	704	490	145	540	606	
CTB765020	762	508	205	726	448	145	508	564	
CTB866420	860	640	205	824	580	145	696	570	
CTB916120	914	610	205	878	550	145	666	559	
CTB987420	980	740	205	944	680	145	700	769	

Dimensions in mm

DIMENSIONAL DRAWING

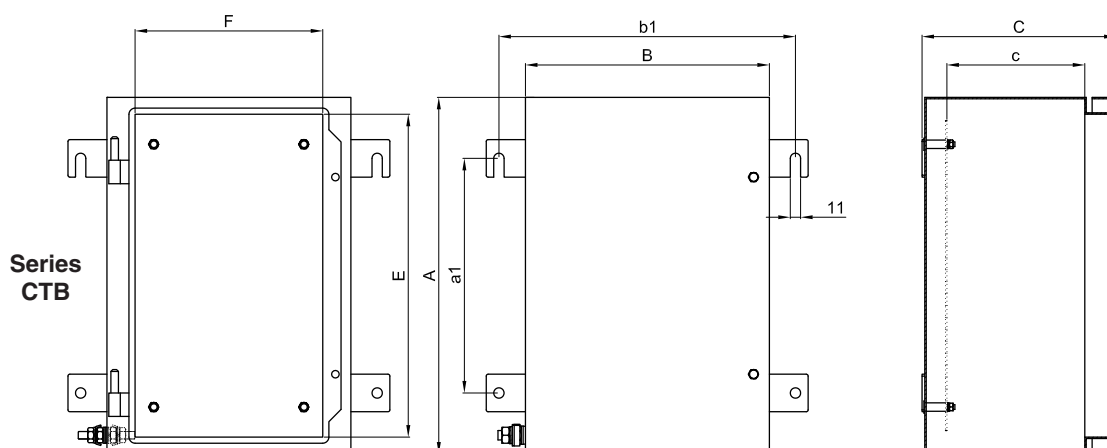
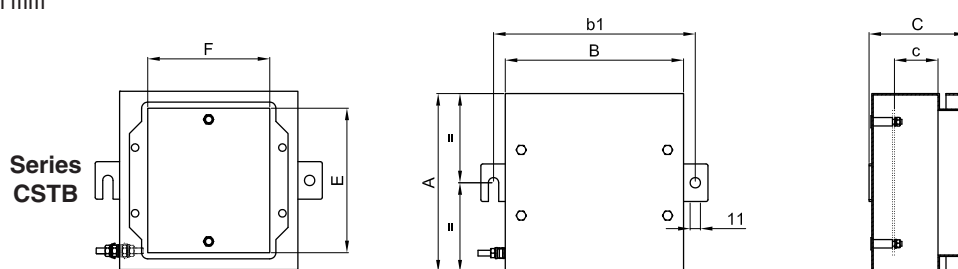

CTB... series (Ex e) and (Ex i) stainless steel junction boxes

Ex e

REMOVABLE GLAND PLATES ON CTB SERIES STAINLESS STEEL BOXES

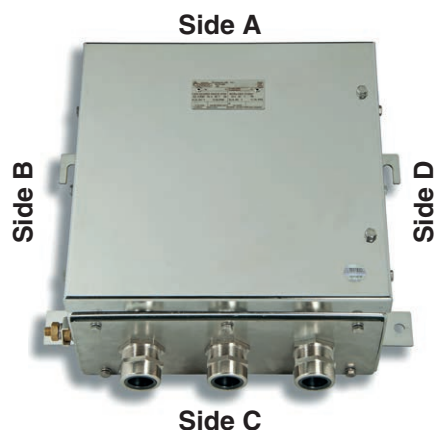

Removable gland plate position coding

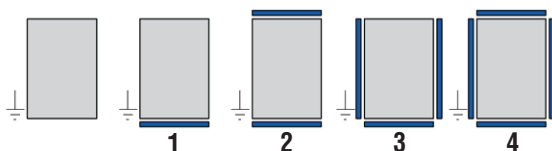

Ordering code examples

1) CTB503516S3

500x350x160 stainless steel box with 3 removable gland plates

2) CTB624520S4

620x450x205 stainless steel box with 4 removable gland plates

Code	Removable gland plate dimensions			
	Side A	Side B	Side C	Side D
CTB221513S..	144x94	144x94	144x94	144x94
CTB262616S..	254x120	154x120	254x120	154x120
CTB262620S..	254x164	154x164	254x164	154x164
CTB303016S..	298x120	254x120	298x120	254x120
CTB303020S..	298x164	254x164	298x164	254x164
CTB382616S..	254x120	298x120	254x120	298x120
CTB382620S..	254x164	298x164	254x164	298x164
CTB453816S..	374x120	374x120	374x120	374x120
CTB453820S..	374x164	374x164	374x164	374x164
CTB484816S..	474x120	444x120	474x120	444x120
CTB484820S..	474x164	444x164	474x164	444x164
CTB503516S..	344x120	444x120	344x120	444x120
CTB503520S..	344x164	444x164	344x164	444x164
CTB624516S..	444x120	544x120	444x120	544x120
CTB624520S..	444x164	544x164	444x164	544x164
CTB745520S..	544x164	634x164	544x164	634x164
CTB765020S..	504x164	594x124	504x164	594x124
CTB808030S..	634x214	634x214	634x214	634x214
CTB866420S..	634x164	740x164	634x164	740x164
CTB916120S..	604x164	740x164	604x164	740x164
CTB987420S..	634x164	444x164 (x2)	634x164	444x164 (x2)

OVERVIEW OF SIZES

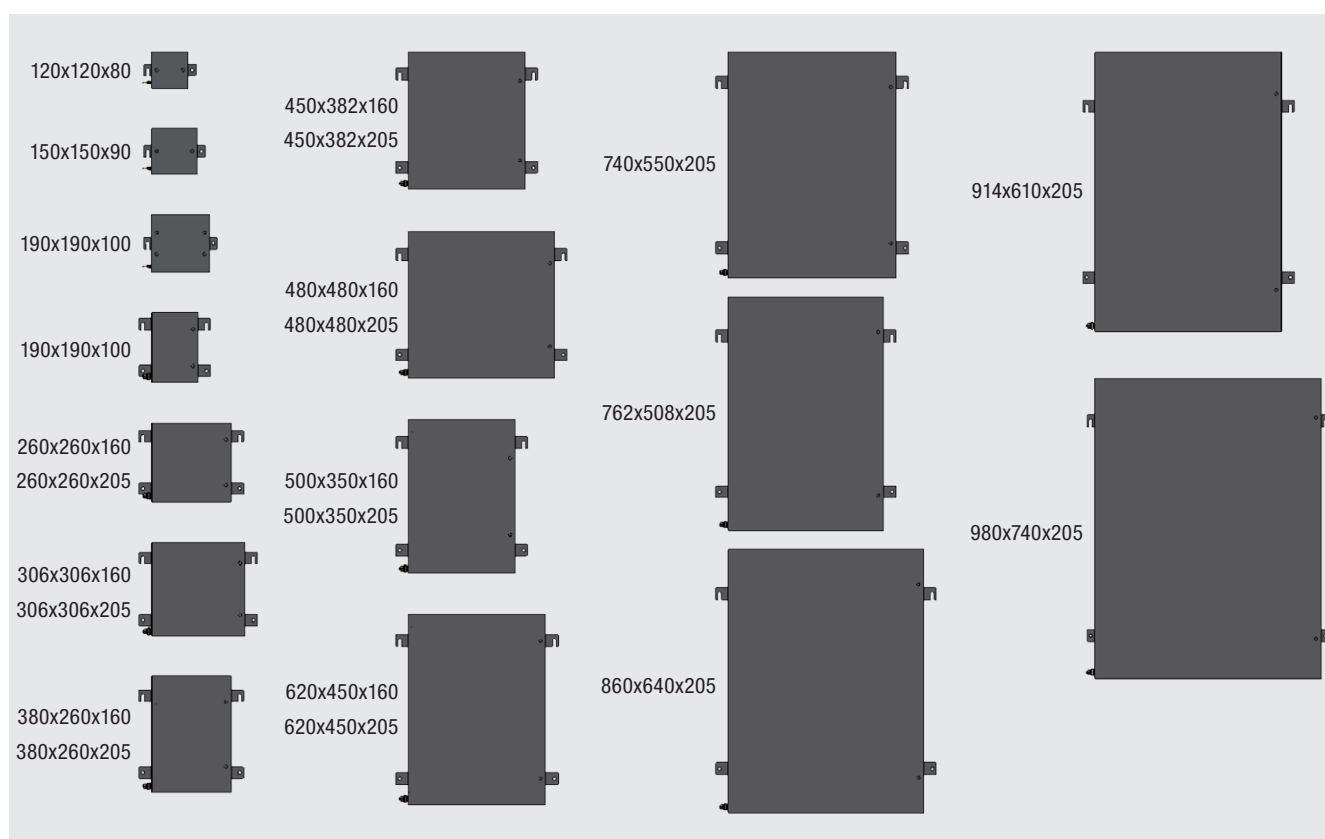

CTB... series Body drilling data

Ex e

THREAD COMPARISON CHART

D Thread diameter	01	1	2	3	4	5	6	7	8
ISO 261/965	16x1.5	20x1.5	25x1.5	32x1.5	40x1.5	50x1.5	63x1.5	75x1.5	90x1.5
Through hole	Ø17	Ø20.5	Ø25.5	Ø32.5	Ø40.5	Ø50.5	Ø63.5	Ø75.5	Ø90.5



As required by the current standard, holes can be drilled by Cortem or by authorized partners who hold a production notification in accordance with ATEX Directive 94/9/EC.

TYPE OF ENCLOSURE	HOLE DRILLING IN BODY																		
	Sides A and C									Sides B and D									
	Drilling area mm	MAXIMUM QUANTITY PER HOLE TYPE								Drilling area mm	MAXIMUM QUANTITY PER HOLE TYPE								
01		1	2	3	4	5	6	7	8		01	1	2	3	4	5	6	7	8
CSTB121208	70x30	2	2	2	-	-	-	-	-	100x30	3	3	3	-	-	-	-	-	-
CSTB151509	115x40	3	3	2	2	-	-	-	-	140x40	4	4	3	2	-	-	-	-	-
CSTB191910	155x50	4	4	3	2	2	-	-	-	180x50	4	4	4	3	3	-	-	-	-
CTB221513	105x55	5	5	2	2	1	-	-	-	165x55	8	8	3	3	3	-	-	-	-
CTB262616	195x80	10	10	7	4	3	3	2	-	210x80	10	10	8	4	3	3	2	-	-
CTB262620	215x125	15	15	14	8	6	3	2	2	195x125	15	15	12	6	6	3	2	2	1
CTB303016	260x80	12	12	10	9	8	3	2	2	245x80	12	12	10	9	8	3	2	2	-
CTB303020	260x125	18	18	17	10	8	6	3	2	245x125	18	18	15	10	8	6	3	2	2
CTB382616	215x80	10	10	10	7	3	3	2	2	315x80	16	16	14	11	5	4	3	3	-
CTB382620	215x125	15	15	12	8	6	6	2	2	315x125	24	24	21	12	10	8	3	3	2
CTB453816	335x80	16	16	14	6	5	4	3	2	385x80	20	20	16	7	6	5	4	3	-
CTB453820	335x125	24	24	21	12	10	8	3	3	335x125	30	30	24	14	12	10	4	3	3
CTB484816	435x80	22	22	18	8	7	6	4	3	405x80	20	20	18	8	6	5	4	3	-
CTB484820	435x125	32	32	26	16	13	11	4	3	405x125	30	30	26	14	12	10	4	3	3
CTB503516	305x80	14	14	12	5	4	4	3	2	440x80	22	22	19	8	7	6	4	4	-
CTB503520	305x125	21	21	18	12	10	7	3	2	440x125	33	33	27	16	14	11	4	4	3
CTB624516	405x80	20	20	18	7	6	5	4	3	555x80	28	28	24	10	9	7	6	5	-
CTB624520	405x125	30	30	26	14	12	10	4	3	550x125	39	39	36	20	18	15	6	5	3
CTB745520	505x125	36	36	32	16	16	13	5	4	670x125	50	50	42	24	21	17	7	6	4
CTB765020	465x125	33	33	29	18	14	11	5	4	690x125	50	50	44	26	22	18	7	6	4
CTB866420	595x125	44	44	38	22	18	15	6	5	780x125	57	57	51	28	24	20	8	6	5
CTB916120	565x125	41	41	35	20	18	14	6	5	830x125	60	60	53	30	26	22	9	7	5
CTB987420	700x125	50	50	44	26	22	18	7	6	420x125(x2)	63	63	59	34	28	24	9	8	6

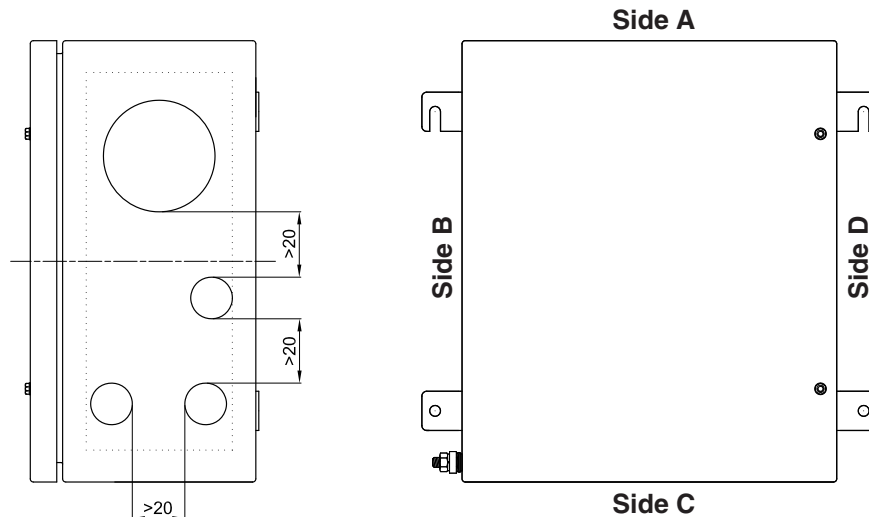

CTB... series Removable gland plate drilling data

Example of enclosure body featuring removable gland plate on just one side.

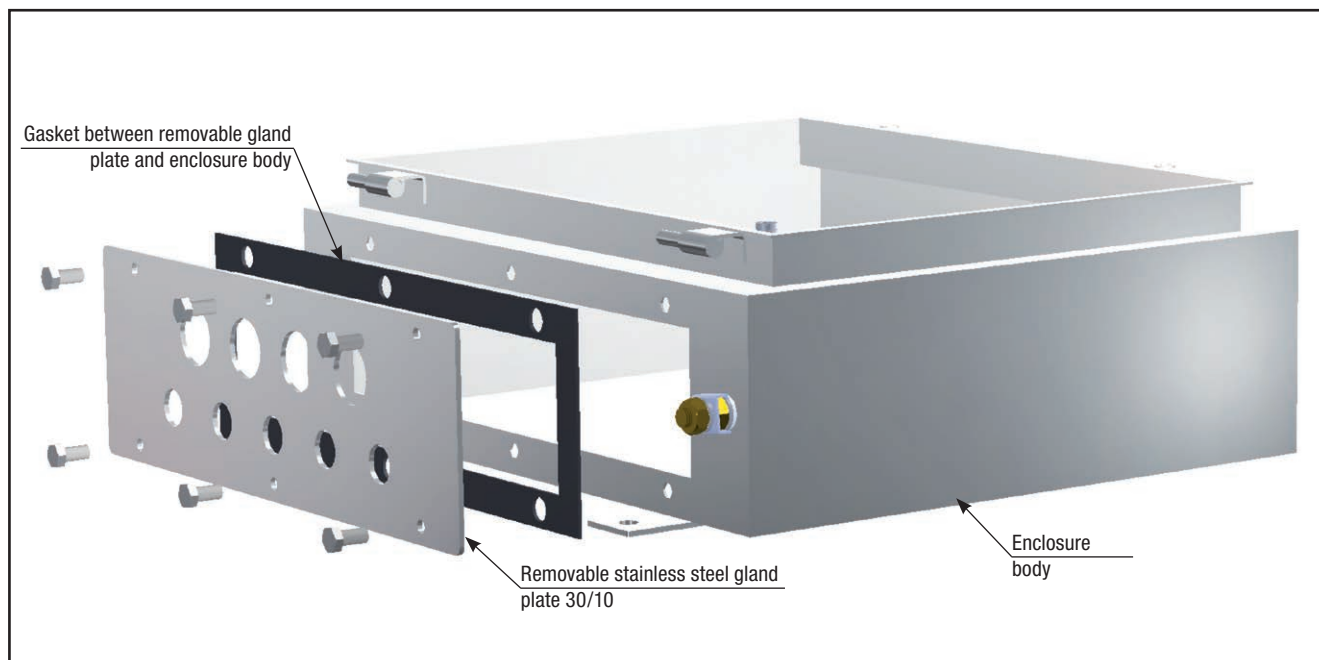

Exe

TYPE OF ENCLOSURE	HOLE DRILLING IN REMOVABLE GLAND PLATES																	
	Sides A and C								Sides B and D									
	Drilling area mm	MAXIMUM QUANTITY PER HOLE TYPE							Drilling area mm	MAXIMUM QUANTITY PER HOLE TYPE								
01		1	2	3	4	5	6	7		01	1	2	3	4	5	6	7	
CTB221513	98x54	3	3	2	1	1	1	-	-	104x54	3	3	2	1	1	1	-	-
CTB262616	214x80	10	10	8	4	3	2	-	-	114x80	6	6	3	2	1	1	-	-
CTB262620	214x124	15	15	12	8	6	3	-	-	114x124	9	9	6	4	2	1	-	-
CTB303016	258x80	12	12	10	4	4	3	2	-	214x80	10	10	8	4	3	3	2	-
CTB303020	258x124	18	18	13	8	4	3	-	-	214x124	15	15	10	8	3	2	-	-
CTB382616	214x80	10	10	8	4	3	3	-	-	258x80	12	12	9	4	3	3	-	-
CTB382620	214x124	15	15	12	8	6	4	-	-	258x124	18	18	15	8	5	3	-	-
CTB453816	334x80	16	16	14	6	5	4	3	-	334x80	16	16	14	6	5	4	3	-
CTB453820	334x124	24	24	20	12	8	4	3	-	334x124	24	24	20	12	8	4	3	-
CTB484816	434x80	22	22	18	7	5	5	4	-	404x80	20	18	14	6	5	4	3	-
CTB484820	434x124	32	32	24	14	12	5	4	-	404x124	29	27	21	12	8	4	3	-
CTB503516	304x80	14	14	12	5	4	4	3	-	404x80	19	16	12	5	4	4	3	-
CTB503520	304x124	21	21	17	10	8	4	3	2	404x124	29	24	18	10	8	4	3	2
CTB624516	404x80	19	19	16	7	6	5	4	-	504x80	24	22	16	7	6	5	4	-
CTB624520	404x124	29	29	23	14	10	5	4	3	504x124	36	33	24	14	12	5	4	3
CTB745520	504x124	36	36	30	16	13	7	5	4	594x124	42	42	30	18	14	7	5	4
CTB765020	464x124	33	33	16	14	10	5	4	3	594x124	42	42	22	22	16	8	5	5
CTB866420	594x124	44	44	36	20	16	8	6	5	700x124	51	48	36	20	16	8	6	4
CTB916120	564x124	41	41	22	16	8	8	4	4	700x124	51	48	22	22	8	8	5	5
CTB987420	594x124	44	44	36	20	16	8	6	4	404x124 (x2)	58	58	48	28	20	10	8	6



These enclosures are customized based on size, on the number of terminals or cables they are due to accommodate, or taking into account the number of cable entries and cabling requirements inside a system. Hence we can produce tailor-made solutions as long as you provide us with the appropriate parameters required at the quote request stage, such as the number of cable glands, unions or sealing fittings to be installed, so that we can determine the most suitable size of enclosure. All terminals can be fitted with your requested accessories and mounted on special rails that are fastened to the enclosure's internal mounting plates. Terminal strips can be arranged in various ways, as specified by the customer and always within the limits allowed by the certificate. The options are vertical, horizontal, in a number of rows, or on different levels using suitable spacers.

ELECTRICAL FEATURES

Rated voltage: 1000 V
Rated frequency: 50 / 60 Hz

Modular terminals

Terminal cross-sectional area: 1.5; 2.5; 4; 6; 10; 25; 35; 70; 95; 120; 185; 240; 300 [mm²]
Rated current: 8 - 400 [A]

Marking	Terminal type	Description
Ex II 2GD Ex e II T... Gb - Ex tb IIIC T... Db IP66	Ex e terminals only	Enclosures containing increased safety terminals to standard EN 60079-7
Ex II 2GD Ex ia IIC T... Gb - Ex ia IIIC T.. Db IP66	Ex e and Ex i terminals	Enclosures containing increased safety terminals and intrinsic safety terminals to standards EN 60079-7 and EN 60079-11
Ex II 2 GD Ex e ia IIC T... Gb - Ex tb ia IIIC T... Db IP66	Ex i terminals only	Enclosures containing intrinsic safety terminals to standard EN 60079-11; enclosures are still category 2

CTB... series Features of junction boxes with terminals

Ex e

Examples of terminal strips with minimum installation distances

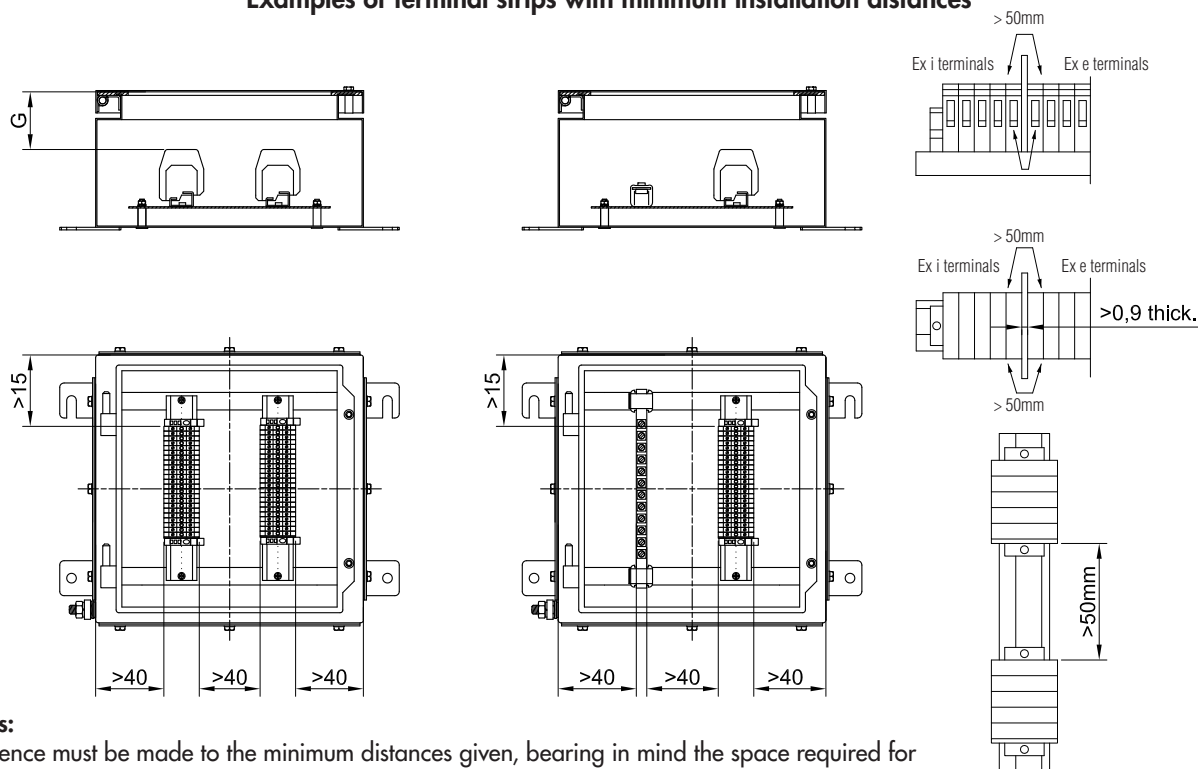

Notes:

Reference must be made to the minimum distances given, bearing in mind the space required for internal wiring.

Only ATEX-certified terminals are allowed inside the enclosures.

Ex i rated terminals must be suitably labelled or coloured differently so they are clearly identifiable.

Ex i cable entries must be suitably identified with either labelling or blue markings on cable glands or the enclosure's sides.

TYPE OF ENCLOSURE	MAXIMUM NUMBER OF TERMINALS HOUSED															
	TERMINAL CROSS-SECTIONAL AREA															
	1.5	2.5	4	6	10	16	25	35	50	70	95	120	150	185	240	300
GSTB121208	8	5	-	-	-	-	-	-	-	-	-	-	-	-	-	-
GSTB151509	28	19	-	-	-	-	-	-	-	-	-	-	-	-	-	-
GSTB191910	16	11	9	7	-	-	-	-	-	-	-	-	-	-	-	-
CTB221513	27	19	15	11	-	-	-	-	-	-	-	-	-	-	-	-
CTB262616	2x36	2x25	2x21	2x16	2x12	2x10	7	-	-	-	-	-	-	-	-	-
CTB262620	2x36	2x25	2x21	2x16	2x12	2x10	7	-	-	-	-	-	-	-	-	-
CTB303016	2x54	2x37	2x31	2x23	2x18	2x15	11	-	-	-	-	-	-	-	-	-
CTB303020	2x54	2x37	2x31	2x23	2x18	2x15	11	11	10	9	-	-	-	-	-	-
CTB382616	2x71	2x49	2x41	2x31	2x24	2x20	15	15	13	11	-	-	-	-	-	-
CTB382620	2x94	2x65	2x54	2x41	2x32	2x27	2x20	2x20	2x18	2x15	-	-	-	-	-	-
CTB453816	2x94	2x65	2x54	2x41	2x32	2x27	2x20	2x20	2x17	2x15	-	-	-	-	-	-
CTB453820	2x94	2x65	2x54	2x41	2x32	2x27	2x20	2x20	2x17	2x15	11	10	10	8	8	6
CTB484816	3x99	3x69	3x58	3x43	2x34	2x28	2x21	2x21	2x18	2x16	-	-	-	-	-	-
CTB484820	3x99	3x69	3x58	3x43	2x34	2x28	2x21	2x21	2x18	2x16	12	10	10	9	9	6
CTB503516	2x105	2x73	2x61	2x46	2x36	2x30	2x22	2x22	2x19	2x17	-	-	-	-	-	-
CTB503520	2x105	2x73	2x61	2x46	2x36	2x30	2x22	2x22	2x19	2x17	13	11	11	10	10	6
CTB624516	3x139	3x97	3x81	3x61	2x48	2x40	2x30	2x30	2x26	2x23	-	-	-	-	-	-
CTB624520	3x139	3x97	3x81	3x61	2x48	2x40	2x30	2x30	2x26	2x23	17	15	15	13	13	9
CTB745520	4x174	4x121	4x101	4x76	3x60	3x50	3x37	3x37	3x33	3x29	22	18	18	16	16	11
CTB765020	4x182	4x127	4x106	4x79	3x63	3x53	3x39	3x39	3x34	3x30	23	19	19	17	17	12
CTB866420	5x208	5x145	5x121	5x91	5x72	5x60	4x45	4x45	3x40	3x35	26	22	22	20	20	13
CTB916120	5x225	5x157	5x131	5x98	5x78	5x65	4x49	4x49	3x43	3x38	29	24	24	21	21	14
CTB987420	5x242	5x169	5x141	5x106	5x84	5x70	4x52	4x52	3x46	3x41	31	26	26	23	23	16

Eg. 2x22= 2 rows of 22 terminals (total 44 terminals). The maximum number of standard terminals refers to the mounting of CABUR and/or WEIDMULLER terminals. The data in the table are given as a rough guide only based solely on the size of the enclosures and the space taken up by the terminals.

The permissible maximum power dissipation, in order to retain a T6 temperature class with an ambient temperature up to 40°C or T5 class with an ambient temperature of 55°C, is not to exceed the values given in the tables below. For an ambient temperature of +60°C or +65°C, maximum power dissipation must be reduced by 25%, and rated current reduced by 15%.

The maximum current values for terminal strips used for low-voltage circuits (signalling units) with a T6 temperature class and maximum ambient temperature of +60°C are as follows:

- 1A for Ex e circuits;
- 100mA for Ex ia circuits.

The values given in the tables on the coming pages refer to the maximum number of conductors allowed for a conductor with a given cross-sectional area and a given maximum current. All incoming wires and active internal links (made by wires) count as wires. Earth connections (i.e. passive connections) do not count.

When DIN/Omega rails are installed on the internal mounting plate (instead of using the relevant mounting plate fastening holes), the number of terminals may be slightly less than the number given in the tables.

Other types of terminals can be used up to the space limit of the box. Whatever the case, all terminals used shall be ATEX and/or IEC Ex certified. Size 35mm² terminals can be used for conductors with a cross-sectional area of 25mm².

The maximum number of terminals and maximum number of rows given in the tables is an indicative value: you must take into account the cable entries on the sides of the boxes. The internal overall dimensions of cable glands/lock nuts and the overall dimensions of conductors must be taken into consideration to allow for wiring.

In some cases, it may be necessary to reduce the number of terminals or the number of rows.

Example of how to calculate the maximum number of conductors.

Referring to table CTB262620: 6 conductors with 6mm² cross-section with 26A continuous current is the limit of this box. Consequently, box CTB262620 is suitable for containing 3 x 6mm² terminals (2 conductors for each terminal) with a max. current of 26A.

There is space for 32 x 6mm² terminals in the box. The remaining 29 terminals (32-3) can be added and used for low-current circuits indicated in the "yellow-coloured" area of the table (in this case max. 8-10A).

Combined mounting for electrical circuits with different sized cables is possible provided the values given are used proportionally.

For example:

Nominal X-sect. area (mm ²)	Current (A)	Quantity	Capacity
2.5	16	10 (out of 30)	33%
16	50	12 (out of 48)	25%
25	63	36 (out of 90)	40%
		Total	98% <100%

CTB... series Features of junction boxes with terminals

Table showing maximum power dissipation and current for ambient temperature +40°C and +55°C

Enclosure	P [W]	Maximum current [A] per conductor cross-sectional area in mm ²															
		1.5	2.5	4	6	10	16	25	35	50	70	95	120	150	185	240	300
CSTB121208	5.3	11	15	21	26	37	49	67	-	-	-	-	-	-	-	-	-
CSTB151509	5.5	11	15	21	26	37	49	67	-	-	-	-	-	-	-	-	-
CSTB191910	6.2	11	15	21	26	37	49	67	-	-	-	-	-	-	-	-	-
CTB221513	6.2	11	15	21	26	37	49	67	-	-	-	-	-	-	-	-	-
CTB262616	10.6	11	15	21	26	37	49	67	-	-	-	-	-	-	-	-	-
CTB262620	11.2	11	15	21	26	37	49	67	-	-	-	-	-	-	-	-	-
CTB303016	11.2	11	15	21	26	37	49	67	-	-	-	-	-	-	-	-	-
CTB303020	12.2	11	15	21	26	37	49	49	67	80	122	122	147	147	147	147	147
CTB382616	12.2	11	15	21	26	37	49	49	67	80	122	122	147	147	147	147	147
CTB382620	12.2	11	15	21	26	37	49	49	67	80	122	122	147	147	147	147	147
CTB453816	29.5	11	15	21	26	37	49	67	80	98	122	147	175	196	227	270	312
CTB453820	29.5	11	15	21	26	37	49	67	80	98	122	147	175	196	227	270	312
CTB484816	29.5	11	15	21	26	37	49	67	80	98	122	147	175	196	227	270	312
CTB484820	29.5	11	15	21	26	37	49	67	80	98	122	147	175	196	227	270	312
CTB503516	29.5	11	15	21	26	37	49	67	80	98	122	147	175	196	227	270	312
CTB503520	29.5	11	15	21	26	37	49	67	80	98	122	147	175	196	227	270	312
CTB624516	36	11	15	21	26	37	49	67	80	98	122	147	175	196	227	270	312
CTB624520	36	11	15	21	26	37	49	67	80	98	122	147	175	196	227	270	312
CTB745520	36	11	15	21	26	37	49	67	80	98	122	147	175	196	227	270	312
CTB765020	36	11	15	21	26	37	49	67	80	98	122	147	175	196	227	270	312
CTB866420	36	11	15	21	26	37	49	67	80	98	122	147	175	196	227	270	312
CTB916120	36	11	15	21	26	37	49	67	80	98	122	147	175	196	227	270	312
CTB987420	36	11	15	21	26	37	49	67	80	98	122	147	175	196	227	270	312

Table showing maximum power dissipation and current for ambient temperature +60°C and +65°C

Enclosure	P [W]	Maximum current [A] per conductor cross-sectional area in mm ²															
		1.5	2.5	4	6	10	16	25	35	50	70	95	120	150	185	240	300
CSTB121208	3.9	9	12	17	22	31	41	57	-	-	-	-	-	-	-	-	-
CSTB151509	4.1	9	12	17	22	31	41	57	-	-	-	-	-	-	-	-	-
CSTB191910	4.6	9	12	17	22	31	41	57	-	-	-	-	-	-	-	-	-
CTB221513	4.6	9	12	17	22	31	41	57	-	-	-	-	-	-	-	-	-
CTB262616	7.9	9	12	17	22	31	41	57	-	-	-	-	-	-	-	-	-
CTB262620	8.4	9	12	17	22	31	41	57	-	-	-	-	-	-	-	-	-
CTB303016	8.4	9	12	17	22	31	41	57	-	-	-	-	-	-	-	-	-
CTB303020	9.1	9	12	17	22	31	41	57	68	83	103	103	125	125	125	125	125
CTB382616	9.1	9	12	17	22	31	41	57	68	83	103	103	125	125	125	125	125
CTB382620	9.1	9	12	17	22	31	41	57	68	83	103	103	125	125	125	125	125
CTB453816	22.1	9	12	17	22	31	41	57	68	83	103	125	148	166	193	229	265
CTB453820	22.1	9	12	17	22	31	41	57	68	83	103	125	148	166	193	229	265
CTB484816	22.1	9	12	17	22	31	41	57	68	83	103	125	148	166	193	229	265
CTB484820	22.1	9	12	17	22	31	41	57	68	83	103	125	148	166	193	229	265
CTB503516	22.1	9	12	17	22	31	41	57	68	83	103	125	148	166	193	229	265
CTB503520	22.1	9	12	17	22	31	41	57	68	83	103	125	148	166	193	229	265
CTB624516	27	9	12	17	22	31	41	57	68	83	103	125	148	166	193	229	265
CTB624520	27	9	12	17	22	31	41	57	68	83	103	125	148	166	193	229	265
CTB745520	27	9	12	17	22	31	41	57	68	83	103	125	148	166	193	229	265
CTB765020	27	9	12	17	22	31	41	57	68	83	103	125	148	166	193	229	265
CTB866420	27	9	12	17	22	31	41	57	68	83	103	125	148	166	193	229	265
CTB916120	27	9	12	17	22	31	41	57	68	83	103	125	148	166	193	229	265
CTB987420	27	9	12	17	22	31	41	57	68	83	103	125	148	166	193	229	265

CTB... series Features of junction boxes with terminals

Instructions for determining which enclosure is best suited based on the planned number of conductors and terminals.

: In this section of the table that has not been filled in, once you have followed the instructions and complied with the values given for the enclosure's internal wiring, you can add as many terminals as you want up to the space limit of the box.

: Any wiring that falls within this section of the table that has not been filled in is not covered by the certificate.

"**C. No.**" row: the values given refer to the maximum number of CABUR terminals physically allowed inside the relevant enclosure. These values are expressed as the product of the rows multiplied by the number of terminals on each row.

"**W. No.**" row: the same as above, but this time referring to Weidmuller terminals.

The terminal brands are mentioned just to give an idea of the quantity of terminals that can be housed inside the enclosure.

The other values given in the cells along the table's diagonal define the maximum number of conductors allowed, based on their cross-sectional area and maximum current.

Tables showing maximum number of conductors

$$(N^{\circ} \text{ of terminals} = \frac{n^{\circ} \text{ of conductors}}{2})$$

CSTB121208

Current (A)	Cross-sectional area in mm ²						
	1.5	2.5	4	6	10	16	25
1							
8	15	25					
10	9	16	22				
11	8	13	18	24			
15		7	10	13			
21			5	7	9	12	
26				4	6	8	10
37					3	4	5
49						2	3
67							2
C. No.							
W. No.	8	5					

Maximum power dissipation with T6 temperature class must not exceed 5.6W

CSTB151509

Current (A)	Cross-sectional area in mm ²						
	1.5	2.5	4	6	10	16	25
1							
8	14	24					
10	9	15	22				
11	7	12	18	24			
15		6	10	13	18	25	
21			5	7	9	13	16
26				4	6	8	11
37					3	4	5
49						2	3
67							2
C. No.							
W. No.	16	11					

Maximum power dissipation with T6 temperature class must not exceed 5.5W

CSTB191910

Current (A)	Cross-sectional area in mm ²						
	1.5	2.5	4	6	10	16	25
1							
8	16	27	38				
10	10	17	24	33			
11	8	14	20	27	39		
15		7	11	14	21	28	
21			6	7	11	14	19
26				5	7	9	12
37					3	5	6
49						3	3
67							2
C. No.							
W. No.	28	19	16	12			

Maximum power dissipation with T6 temperature class must not exceed 6.2W

CTB221513

Current (A)	Cross-sectional area in mm ²						
	1.5	2.5	4	6	10	16	25
1							
8	16	27	38				
10	10	17	24	33			
11	8	14	20	27	39		
15		7	11	14	21	28	
21			6	7	11	14	19
26				5	7	9	12
37					3	5	6
49						3	3
67							2
C. No.		17	14	11			
W. No.	27	19	15	11			

Maximum power dissipation with T6 temperature class must not exceed 6.2W

CTB262616

Current (A)	Cross-sectional area in mm ²						
	1.5	2.5	4	6	10	16	25
1							
8	20	33	49	68	103		
10	13	21	32	44	66		
11	11	18	26	36	54	77	107
15		9	14	19	29	41	57
21			7	10	15	21	29
26				6	10	15	19
37					5	7	9
49						4	5
67							3
C. No.		2x23	2x19	2x16	2x12	2x10	7
W. No.	2x36	2x25	2x21	2x16	2x12	2x10	7

Maximum power dissipation with T6 temperature class must not exceed 10.6W

CTB262620

Current (A)	Cross-sectional area in mm ²						
	1.5	2.5	4	6	10	16	25
1							
8	20	33	49	68	103		
10	13	21	32	44	66		
11	11	18	26	36	54	77	107
15		9	14	19	29	41	57
21			7	10	15	21	29
26				6	10	14	19
37					5	7	9
49						4	5
67							3
C. No.		2x23	2x19	2x16	2x12	2x10	7
W. No.	2x36	2x25	2x21	2x16	2x12	2x10	7

Maximum power dissipation with T6 temperature class must not exceed 11.2W

CTB303016

Current (A)	Cross-sectional area in mm ²						
	1.5	2.5	4	6	10	16	25
1							
8	20	33	49	68	103		
10	13	21	32	44	66		
11	11	18	26	36	54	77	107
15		9	14	19	29	41	57
21			7	10	15	21	29
26				6	10	14	19
37					5	7	9
49						4	5
67							3
C. No.		2x34	2x28	2x23	2x18	2x15	11
W. No.	2x54	2x37	2x31	2x23	2x18	2x15	11

Maximum power dissipation with T6 temperature class must not exceed 11.2W

CTB... series Features of junction boxes with terminals

Exe

Tables showing maximum number of conductors

CTB303020

Current (A)	Cross-sectional area in mm ²															
	1.5	2.5	4	6	10	16	25	35	50	70	95	120	150	185	240	300
1																
8	21	34	51	71	107	153										
10	13	22	33	45	69	98	136									
11	11	18	27	38	57	81	113	141								
15		9	15	20	31	43	61	76	92							
21			7	10	16	22	31	39	47	59						
26				7	10	14	20	25	31	38	45					
37					5	7	10	12	15	19	22	25	27			
49						4	6	7	9	11	13	14	15	16	17	
67							3	4	5	6	7	8	8	9	9	5
80								3	3	4	5	5	6	6	6	4
98									2	3	3	4	4	4	4	2
122										2	2	2	2	3	3	2
147											2	2	2	2	2	2
C. No.		2x34	2x28	2x23	2x18	2x15	11	11	10	9						
W. No.	2x54	2x37	2x31	2x23	2x18	2x15	11	11	10	9						

Maximum power dissipation with T6 temperature class must not exceed 12.2W

CTB382616, CTB382620

Current (A)	Cross-sectional area in mm ²															
	1.5	2.5	4	6	10	16	25	35	50	70	95	120	150	185	240	300
1																
8	21	34	51	71	107	153										
10	13	22	33	45	69	98	136									
11	11	18	27	38	57	81	113	141								
15		9	15	20	31	43	61	76	92							
21			7	10	16	22	31	39	47	59						
26				7	10	14	20	25	31	38	45					
37					5	7	10	12	15	19	22	25	27			
49						4	6	7	9	11	13	14	15	16	17	
67							3	4	5	6	7	8	8	9	9	5
80								3	3	4	5	5	6	6	6	4
98									2	3	3	4	4	4	4	2
122										2	2	2	2	3	3	2
147											2	2	2	2	2	2
C. No.		2x45	2x38	2x31	2x24	2x20	15	15	13	11						
W. No.	2x71	2x49	2x41	2x31	2x24	2x20	15	15	13	11						

Maximum power dissipation with T6 temperature class must not exceed 12.2W

CTB453816

Current (A)	Cross-sectional area in mm ²															
	1.5	2.5	4	6	10	16	25	35	50	70	95	120	150	185	240	300
1																
8	39	65	98	139	215	316										
10	25	41	63	89	138	202	291									
11	21	34	52	73	114	167	241	311								
15		18	28	39	61	90	129	167	209							
21			14	20	31	46	66	85	107	141						
26				13	20	30	43	56	70	92	115					
37					10	15	21	27	34	45	57	66	76			
49						8	12	16	20	26	32	38	43	49		
67							6	8	10	14	17	20	23	26	31	
80								6	7	10	12	14	16	19	22	16
98									5	6	8	9	11	12	14	11
122										4	5	6	7	8	9	11
147											4	4	5	5	6	7
175												3	3	4	4	5
196													3	3	4	4
227														2	3	3
270															2	2
312																2
C. No.		2x59	2x50	2x41	2x32	2x27	2x20	2x20	2x18	2x15						
W. No.	2x94	2x65	2x54	2x41	2x32	2x27	2x20	2x20	2x17	2x15						

Maximum power dissipation with T6 temperature class must not exceed 29.5W

CTB453820

Current (A)	Cross-sectional area in mm ²															
	1.5	2.5	4	6	10	16	25	35	50	70	95	120	150	185	240	300
1																
8	39	65	98	139	215	316										
10	25	41	63	89	138	202	291									
11	21	34	52	73	114	167	241	311								
15		18	28	39	61	90	129	167	209							
21			14	20	31	46	66	85	107	141						
26				13	20	30	43	56	70	92	115					
37					10	15	21	27	34	45	57	66	76			
49						8	12	16	20	26	32	38	43	49		
67							6	8	10	14	17	20	23	26	31	
80								6	7	10	12	14	16	19	22	16
98									5	6	8	9	11	12	14	11
122										4	5	6	7	8	9	11
147											4	4	5	5	6	7
175												3	3	4	4	5
196													3	3	4	4
227														2	3	3
270															2	2
312																2
C. No.		2x59	2x50	2x41	2x32	2x27	2x20	2x20	2x18	2x15	10	7	7	6	6	6
W. No.	2x94	2x65	2x54	2x41	2x32	2x27	2x20	2x20	2x17	2x15	11	10	10	8	8	8

Maximum power dissipation with T6 temperature class must not exceed 29.5W

CTB... series Features of junction boxes with terminals

Ex e

Codes of terminals used to determine maximum number of terminals

The other values given in the cells along the table's diagonal define the maximum number of conductors allowed, based on their cross-sectional area and maximum current.

mm ²	1.5	2.5	4	6	10	16	25	35
Cabur		CBD 2	CBD 4	CBD 6	CBD 10	CBD 16	CBD 35	
Weidmuller	WDU 1.5	WDU 2.5	WDU 4	WDU 6	WDU 10	WDU 16	WDU 35	

mm ²	50	70	95	120	150	185	240	300
Cabur	CBD 50	CBD 70	GPM95/CC	GPM150/CC		GPM240/CC		
Weidmuller	WDU 50	WDU 70	WDU 70/95	WDU 120/150		WDU 240		

ATEX - IECEx label for terminal enclosures

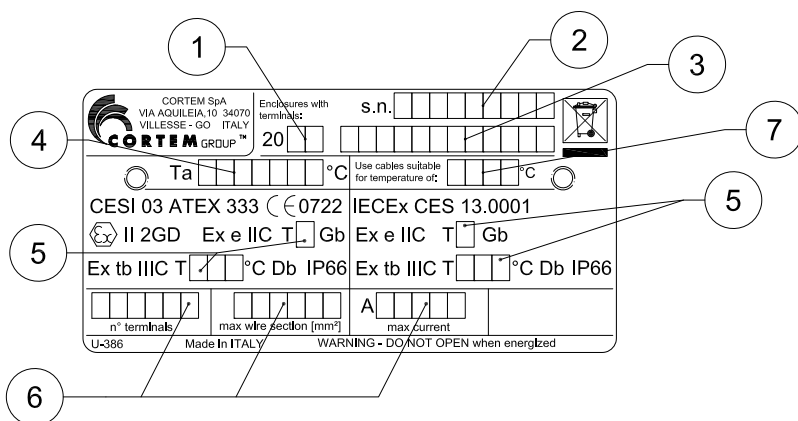

Data filled in:

1. year of manufacture
2. serial number
3. product code
4. ambient temperature
5. temperature class and maximum surface temperature
6. electrical specs per certificate
7. temperature of cables

TYPICAL EXAMPLES OF TERMINAL BLOCK INSTALLATION

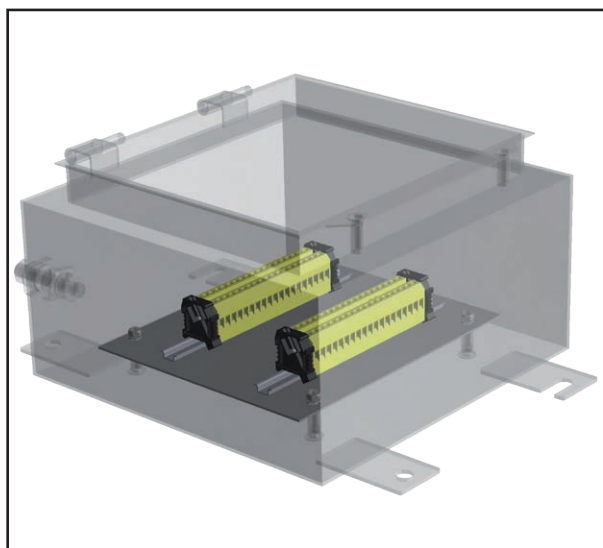

Example of feed-through terminal installation on top hat rail fastened to stainless steel internal mounting plate.

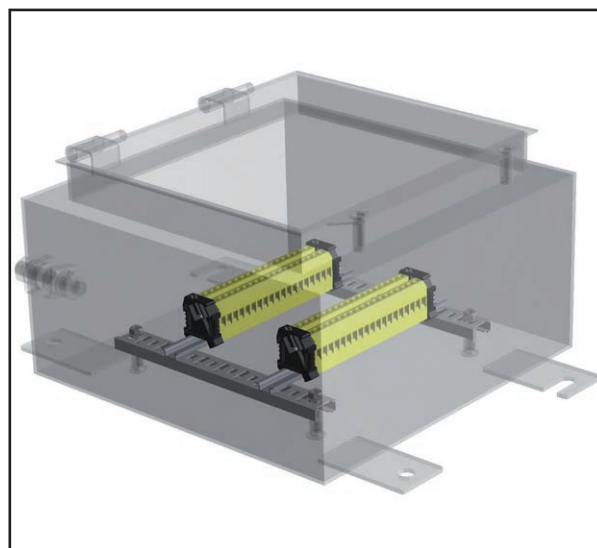

Example of feed-through terminal installation on top hat rail fastened on two pre-drilled mounting rails.

DON'T FORGET TO ORDER THE ACCESSORIES

Example: Enclosure type **CTB484820** + Terminal mounting rails **OBO2060/S** + Cable glands, unions + other...see key







CTB... series Accessories available on request and spare parts

Ex e

ILLUSTRATION	DESCRIPTION	MODEL	DIMENSIONS		CODE	KEY
			A	B		
	Internal mounting plates Stainless steel	CTB221513	155	80	B22-443	 
		CTB262616	210	180	B26-443	
		CTB262620				
		CTB303016	250	230	B30-443	
		CTB303020				
		CTB382616	330	180	B38-443	
		CTB382620				
		CTB453816	400	300	B45-443	
		CTB453820				
		CTB484816	430	400	B48-443	
		CTB484820				
		CTB503516	450	270	B50-443	
		CTB503520				
		CTB624516	570	370	B62-443	
		CTB624520				
		CTB745520	690	470	B74-443	
CTB765020	710	430	B76-443			
CTB866420	810	560	B86-443			
CTB916120	860	530	B91-443			
CTB987420	930	660	B98-443			
ILLUSTRATION	DESCRIPTION	MODEL	FEATURES		CODE	KEY
	Terminal block mounting rails		Pre-drilled steel rails cut to size		OB02060/S	 
	Universal clip for grouping cables in single bundle	For 6-13mm cable	Material: polyamide Hole for M6 screw for fastening		OB02037/6-13	 
		For 12-20mm cable			OB02037/12-20	
		For 16-24mm cable			OB02037/16-24	
		For 18-30mm cable			OB02037/18-30	
		For 27-43mm cable			OB02037/27-43	
	Breather and drain valve	Thread diameter ISO 7-R 3/8"	Material: stainless steel		ECD-210S	 
	Through earth connection	M6	Material: stainless steel		K-0307/1	 
		M8			K-0307/2	
	Entry blanking plugs and cable glands	For models and codes, visit www.cortemgroup.com				 
	Sealed bushings, adapters and reducers					
	Lid-mounted control and signalling devices	For control and signalling device models and codes, see control and monitoring device chapter			M-0... (Ex de)	 

CTB... series Accessories available on request and spare parts

Exe

ILLUSTRATION	DESCRIPTION	MODEL	CODE	KEY
	Gasket between body and lid	CSTB121208	B12-446	
		CSTB151509	B15-446	
		CSTB191910	B19-446	
		CTB221513	B22-446	
		CTB262616	B26-446	
		CTB262620	B26-446	
		CTB303016	B30-446	
		CTB303020	B30-446	
		CTB382616	B38-446	
		CTB382620	B38-446	
		CTB453816	B45-446	
		CTB453820	B45-446	
		CTB484816	B48-446	
		CTB484820	B48-446	
		CTB503516	B50-446	
		CTB503520	B50-446	
		CTB624516	B62-446	
		CTB624520	B62-446	
		CTB745520	B74-446	
		CTB765020	B76-446	
CTB866420	B86-446			
CTB916120	B91-446			
CTB987420	B98-446			
	Gasket between removable gland plates and body	B1-444	B1-445	
		B2-444	B2-445	
		B3-444	B3-445	
		B4-444	B4-445	
		B5-444	B5-445	
		B6-444	B6-445	
		B7-444	B7-445	
		B8-444	B8-445	
		B9-444	B9-445	
		B10-444	B10-445	
		B11-444	B11-445	
		B12-444	B12-445	
		B13-444	B13-445	
		B14-444	B14-445	
		B15-444	B15-445	
		B16-444	B16-445	
		B17-444	B17-445	
		B18-444	B18-445	
		B19-444	B19-445	
		B20-444	B20-445	
		B21-444	B21-445	
		B22-444	B22-445	

CTB... series (Ex e) and (Ex i) stainless steel junction boxes

Ex e

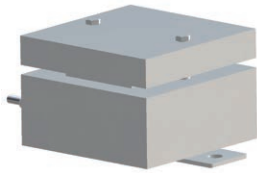

Zone 1,2,21,22.
Degree of protection IP66.
Stainless steel body and lid.
Acid/hydrocarbon-resistant gasket.
Stainless steel bolts and screws.
Impact protection IK10.

Ordering details

Standard stainless steel enclosure: **CSTB121208**

Width/Depth/Height: **120/120/80mm**

Certification data for enclosures with terminals

Group II Category 2GD

Zone 1- Zone 2 (Gas) Zone 21 - Zone 22 (Dust)

II 2GD Ex e IIC T.. Gb - Ex tb IIIC T.. Db IP66

II 2GD Ex ia IIC T.. Gb - Ex ia IIIC T.. Db IP66

II 2GD Ex e ia IIC T.. Gb - Ex tb ia IIIC T.. Db IP66

Ambient temperature: -40°C +55°C (+40°C)

Certification:

CESI 03 ATEX 333 (ATEX)

IEC Ex CES 13.0001 (IECEX)

Russian (GOST R)

Accessories

	CODE
Breather and drain valve:	ECD-210S

Other:

Internal anti-condensation coating

External epoxy coatings in different colour

Terminals

M6 or M8 through earth connection

Plugs, cable glands, adapters, sealed bushings

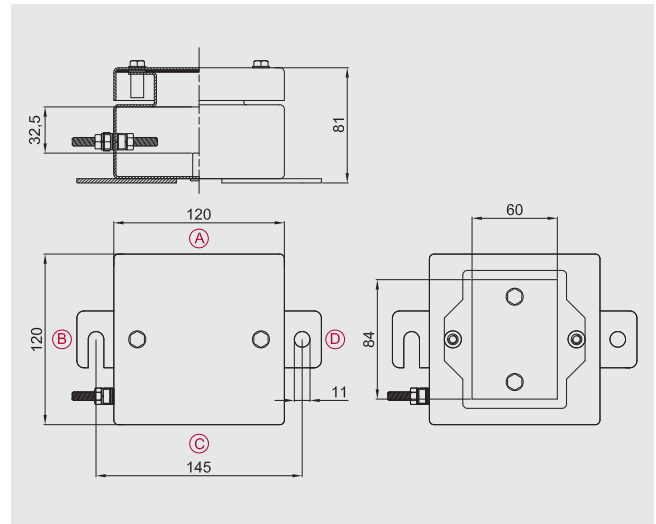

Max. number of terminals

X-SECT.	QTY.
1.5 mm ²	8
2.5 mm ²	5



Eg. 2x22= 2 rows of 22 terminals (total 44 terminals). The maximum number of standard terminals refers to the mounting of CABUR and/or WEIDMULLER terminals.

The data in the table are given as a rough guide only based solely on the size of the enclosures and the space taken up by the terminals.

Number of cable glands

Hole type	Standard enclosure	
	A/C	B/D
M16	2	3
M20	2	3
M25	2	3



Research conducted using Cortem's new REV and REVD series cable glands.

As required by the current standard, holes can be drilled by Cortem or by authorized partners who hold a production notification in accordance with ATEX Directive 94/9/EC.

CTB... series (Ex e) and (Ex i) stainless steel junction boxes

Ex e

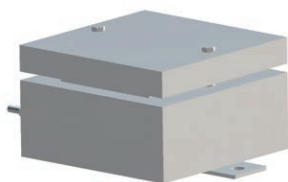

Zone 1,2,21,22.
 Degree of protection IP66.
 Stainless steel body and lid.
 Acid/hydrocarbon-resistant gasket.
 Stainless steel bolts and screws.
 Impact protection IK10.

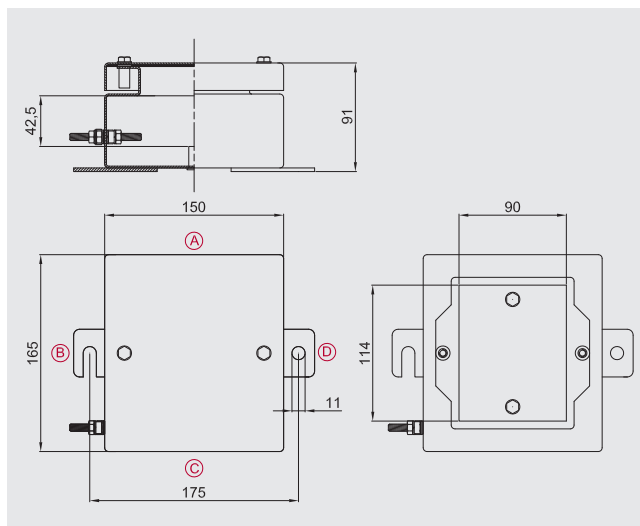

Ordering details

Standard stainless steel enclosure:	CSTB151509
Width/Depth/Height:	150/150/90mm

Certification data for enclosures with terminals

Group II Category 2GD
Zone 1 - Zone 2 (Gas) Zone 21 - Zone 22 (Dust)
II 2GD Ex e IIC T.. Gb - Ex tb IIIC T.. Db IP66
II 2GD Ex ia IIC T.. Gb - Ex ia IIIC T.. Db IP66
II 2GD Ex e ia IIC T.. Gb - Ex tb ia IIIC T.. Db IP66
Ambient temperature: -40°C +55°C (+40°C)

Certification:

CESI 03 ATEX 333 (ATEX)
 IEC Ex CES 13.0001 (IECEX)
 Russian (GOST R)

Accessories

	CODE
Breather and drain valve:	ECD-210S

Other:

Internal anti-condensation coating
 External epoxy coatings in different colour
 Terminals
 M6 or M8 through earth connection
 Plugs, cable glands, adapters, sealed bushings

Max. number of terminals

X-SECT.	QTY.
1.5 mm ²	28
2.5 mm ²	19



Eg. 2x22= 2 rows of 22 terminals (total 44 terminals). The maximum number of standard terminals refers to the mounting of CABUR and/or WEIDMULLER terminals.
 The data in the table are given as a rough guide only based solely on the size of the enclosures and the space taken up by the terminals.

Number of cable glands

Standard enclosure		
Hole type	A/C	B/D
M16	3	4
M20	3	4
M25	2	3
M32	2	2



Research conducted using Cortem's new REV and REVD series cable glands.

As required by the current standard, holes can be drilled by Cortem or by authorized partners who hold a production notification in accordance with ATEX Directive 94/9/EC.

CTB... series (Ex e) and (Ex i) stainless steel junction boxes

Ex e

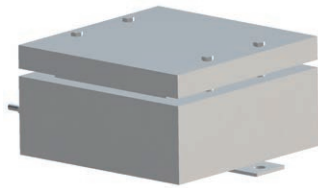

Zone 1,2,21,22.
Degree of protection IP66.
Stainless steel body and lid.
Acid/hydrocarbon-resistant gasket.
Stainless steel bolts and screws.
Impact protection IK10.

Ordering details

Standard stainless steel enclosure: **CSTB191910**

Width/Depth/Height: **190/190/100mm**

Certification data for enclosures with terminals

Group II Category 2GD

Zone 1- Zone 2 (Gas) Zone 21 - Zone 22 (Dust)

II 2GD Ex e IIC T.. Gb - Ex tb IIIC T.. Db IP66

II 2GD Ex ia IIC T.. Gb - Ex ia IIIC T.. Db IP66

II 2GD Ex e ia IIC T.. Gb - Ex tb ia IIIC T.. Db IP66

Ambient temperature: -40°C +55°C (+40°C)

Certification:

CESI 03 ATEX 333 (ATEX)

IEC Ex CES 13.0001 (IECEX)

Russian (GOST R)

Accessories

	CODE
Breather and drain valve:	ECD-210S

Other:

Internal anti-condensation coating
External epoxy coatings in different colour
Terminals
M6 or M8 through earth connection
Plugs, cable glands, adapters, sealed bushings

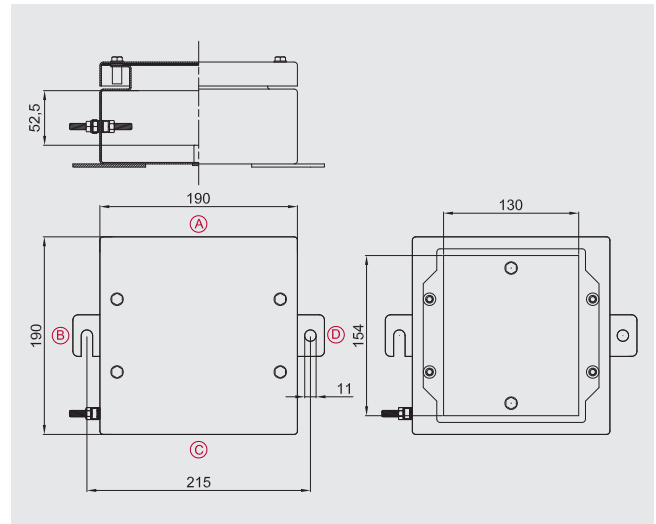

Max. number of terminals

X-SECT.	QTY.
1.5 mm ²	16
2.5 mm ²	11
4 mm ²	9
6 mm ²	7



Eg. 2x22= 2 rows of 22 terminals (total 44 terminals). The maximum number of standard terminals refers to the mounting of CABUR and/or WEIDMULLER terminals.

The data in the table are given as a rough guide only based solely on the size of the enclosures and the space taken up by the terminals.

Number of cable glands

Hole type	Standard enclosure	
	A/C	B/D
M16	4	4
M20	4	4
M25	3	4
M32	2	3
M40	2	3



Research conducted using Cortem's new REV and REVD series cable glands.

As required by the current standard, holes can be drilled by Cortem or by authorized partners who hold a production notification in accordance with ATEX Directive 94/9/EC.

CTB... series (Ex e) and (Ex i) stainless steel junction boxes

Ex e

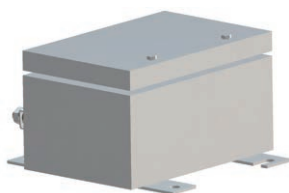

Zone 1,2,21,22.
Degree of protection IP66.
Stainless steel body and lid.
Acid/hydrocarbon-resistant gasket.
Stainless steel bolts and screws.
Impact protection IK10.

Ordering details

Standard stainless steel enclosure:	CTB221513
Width/Depth/Height:	229/152/130mm

Certification data for enclosures with terminals

Group II Category 2GD
Zone 1 - Zone 2 (Gas) Zone 21 - Zone 22 (Dust)
II 2GD Ex e IIC T.. Gb - Ex tb IIIC T.. Db IP66
II 2GD Ex ia IIC T.. Gb - Ex ia IIIC T.. Db IP66
II 2GD Ex e ia IIC T.. Gb - Ex tb ia IIIC T.. Db IP66
Ambient temperature: -40°C +55°C (+40°C)

Certification:

CESI 03 ATEX 333 (ATEX)
IEC Ex CES 13.0001 (IECEX)
Russian (GOST R)

Accessories

	CODE
2.5mm-thick stainless steel internal mounting plate:	B22-443
Terminal block mounting rails:	OBO2060/S
Breather and drain valve:	ECD-210S

Other:

Padlocking system
Internal anti-condensation coating
External epoxy coatings in different colour
Terminals
Clip for grouping cables in single bundle
M6 or M8 through earth connection
Plugs, cable glands, adapters, sealed bushings

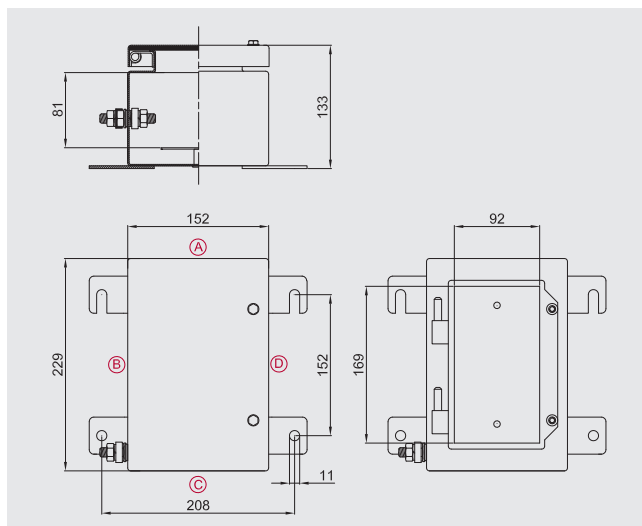

Ordering details for boxes with removable gland plates

Removable gland plate position coding

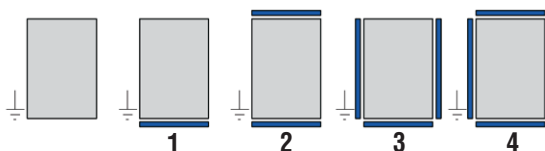

Ordering code examples

- CTB503516S3**
500x350x160 stainless steel box with 3 removable gland plates
- CTB624520S4**
620x450x205 stainless steel box with 4 removable gland plates

Max. number of terminals

X-SECT.	QTY.
1.5 mm ²	27
2.5 mm ²	19
4 mm ²	15
6 mm ²	11



Eg. 2x22= 2 rows of 22 terminals (total 44 terminals). The maximum number of standard terminals refers to the mounting of CABUR and/or WEIDMULLER terminals.
The data in the table are given as a rough guide only based solely on the size of the enclosures and the space taken up by the terminals.

Number of cable glands

Standard enclosure			With removable gland plates		
Hole type	A/C	B/D	Hole type	A/C	B/D
M16	5	8	M16	3	3
M20	5	8	M20	3	3
M25	2	3	M25	2	2
M32	2	3	M40	1	1
M40	1	3	M50	1	1
			M63	1	1



Research conducted using Cortem's new REV and REVD series cable glands.

As required by the current standard, holes can be drilled by Cortem or by authorized partners who hold a production notification in accordance with ATEX Directive 94/9/EC.

CTB... series (Ex e) and (Ex i) stainless steel junction boxes

Ex e

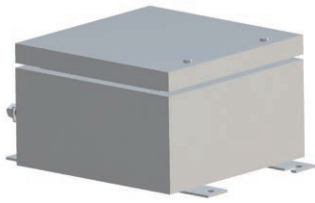

Zone 1,2,21,22.
Degree of protection IP66.
Stainless steel body and lid.
Acid/hydrocarbon-resistant gasket.
Stainless steel bolts and screws.
Impact protection IK10.

Ordering details

Standard stainless steel enclosure: **CTB262616**

Width/Depth/Height: **260/260/160mm**

Certification data for enclosures with terminals

Group II Category 2GD

Zone 1- Zone 2 (Gas) Zone 21 - Zone 22 (Dust)

II 2GD Ex e IIC T.. Gb - Ex tb IIIC T.. Db IP66

II 2GD Ex ia IIC T.. Gb - Ex ia IIIC T.. Db IP66

II 2GD Ex e ia IIC T.. Gb - Ex tb ia IIIC T.. Db IP66

Ambient temperature: -40°C +55°C (+40°C)

Certification:

CESI 03 ATEX 333 (ATEX)

IEC Ex CES 13.0001 (IECEX)

Russian (GOST R)

Accessories

	CODE
2.5mm-thick stainless steel internal mounting plate:	B26-443
Terminal block mounting rails:	OBO2060/S
Breather and drain valve:	ECD-210S

Other:

Padlocking system

Internal anti-condensation coating

External epoxy coatings in different colour

Terminals

Clip for grouping cables in single bundle

M6 or M8 through earth connection

Plugs, cable glands, adapters, sealed bushings

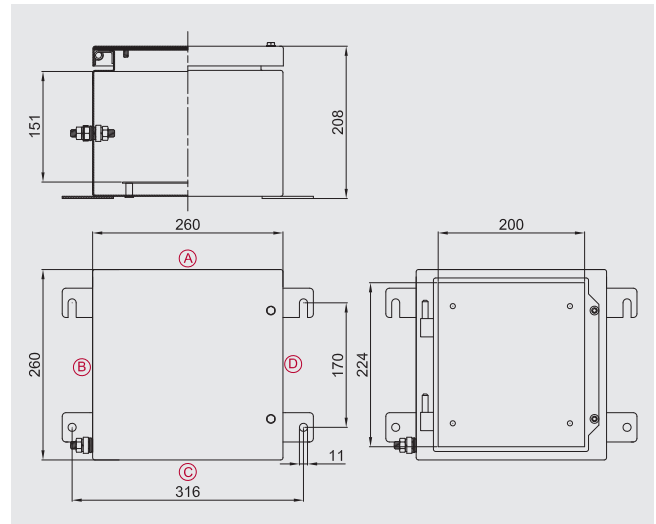

Ordering details for boxes with removable gland plates

Removable gland plate position coding

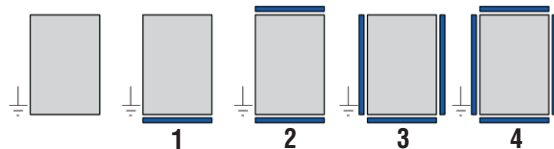

Ordering code examples

1) CTB503516S3

500x350x160 stainless steel box with 3 removable gland plates

2) CTB624520S4

620x450x205 stainless steel box with 4 removable gland plates

Max. number of terminals

X-SECT.	QTY.
1.5 mm ²	2x36
2.5 mm ²	2x25
4 mm ²	2x21
6 mm ²	2x16
10 mm ²	2x12
16 mm ²	2x10
25 mm ²	7



Eg. 2x22= 2 rows of 22 terminals (total 44 terminals). The maximum number of standard terminals refers to the mounting of CABUR and/or WEIDMULLER terminals.

The data in the table are given as a rough guide only based solely on the size of the enclosures and the space taken up by the terminals.

Number of cable glands

Standard enclosure			With removable gland plates		
Hole type	A/C	B/D	Hole type	A/C	B/D
M20	10	10	M20	10	6
M25	7	8	M25	8	3
M32	4	4	M32	4	2
M40	3	3	M40	3	1
M50	3	3	M50	2	1
M63	2	2	M63	-	-



Research conducted using Cortem's new REV and REVD series cable glands.

As required by the current standard, holes can be drilled by Cortem or by authorized partners who hold a production notification in accordance with ATEX Directive 94/9/EC.

CTB... series (Ex e) and (Ex i) stainless steel junction boxes

Ex e

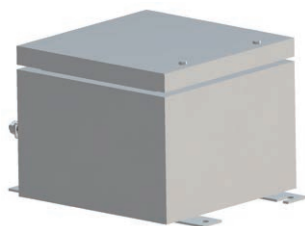

Zone 1,2,21,22.
Degree of protection IP66.
Stainless steel body and lid.
Acid/hydrocarbon-resistant gasket.
Stainless steel bolts and screws.
Impact protection IK10.

Ordering details

Standard stainless steel enclosure:	CTB262620
Width/Depth/Height:	260/260/205mm

Certification data for enclosures with terminals

Group II Category 2GD
Zone 1 - Zone 2 (Gas) Zone 21 - Zone 22 (Dust)
II 2GD Ex e IIC T.. Gb - Ex tb IIIC T.. Db IP66
II 2GD Ex ia IIC T.. Gb - Ex ia IIIC T.. Db IP66
II 2GD Ex e ia IIC T.. Gb - Ex tb ia IIIC T.. Db IP66
Ambient temperature: -40°C +55°C (+40°C)

Certification:

CESI 03 ATEX 333 (ATEX)
IEC Ex CES 13.0001 (IECEX)
Russian (GOST R)

Accessories

	CODE
2.5mm-thick stainless steel internal mounting plate:	B26-443
Terminal block mounting rails:	OBO2060/S
Breather and drain valve:	ECD-210S

Other:

Padlocking system
Internal anti-condensation coating
External epoxy coatings in different colour
Terminals
Clip for grouping cables in single bundle
M6 or M8 through earth connection
Plugs, cable glands, adapters, sealed bushings

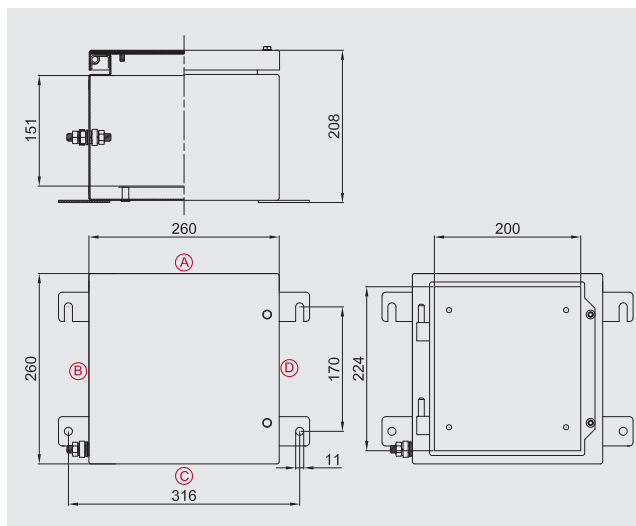

Ordering details for boxes with removable gland plates

Removable gland plate position coding

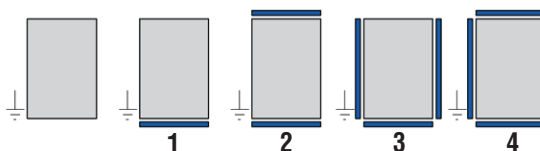

Ordering code examples

- CTB503516S3**
500x350x160 stainless steel box with 3 removable gland plates
- CTB624520S4**
620x450x205 stainless steel box with 4 removable gland plates

Max. number of terminals

X-SECT.	QTY.
1.5 mm ²	2x36
2.5 mm ²	2x25
4 mm ²	2x21
6 mm ²	2x16
10 mm ²	2x12
16 mm ²	2x10
25 mm ²	7



Eg. 2x22= 2 rows of 22 terminals (total 44 terminals). The maximum number of standard terminals refers to the mounting of CABUR and/or WEIDMULLER terminals.
The data in the table are given as a rough guide only based solely on the size of the enclosures and the space taken up by the terminals.

Number of cable glands

Standard enclosure			With removable gland plates		
Hole type	A/C	B/D	Hole type	A/C	B/D
M20	15	15	M20	15	9
M25	14	12	M25	12	6
M32	8	6	M32	8	4
M40	6	6	M40	6	2
M50	3	3	M50	3	1
M63	2	2			



Research conducted using Cortem's new REV and REVD series cable glands.

As required by the current standard, holes can be drilled by Cortem or by authorized partners who hold a production notification in accordance with ATEX Directive 94/9/EC.

CTB... series (Ex e) and (Ex i) stainless steel junction boxes

Ex e

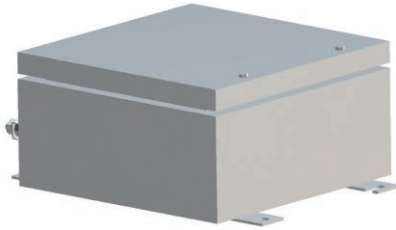

Zone 1,2,21,22.
Degree of protection IP66.
Stainless steel body and lid.
Acid/hydrocarbon-resistant gasket.
Stainless steel bolts and screws.
Impact protection IK10.

Ordering details

Standard stainless steel enclosure: **CTB303016**

Width/Depth/Height: **306/306/160mm**

Certification data for enclosures with terminals

Group II Category 2GD

Zone 1 - Zone 2 (Gas) Zone 21 - Zone 22 (Dust)

II 2GD Ex e IIC T.. Gb - Ex tb IIIC T.. Db IP66

II 2GD Ex ia IIC T.. Gb - Ex ia IIIC T.. Db IP66

II 2GD Ex e ia IIC T.. Gb - Ex tb ia IIIC T.. Db IP66

Ambient temperature: -40°C +55°C (+40°C)

Certification:

CESI 03 ATEX 333 (ATEX)

IEC Ex CES 13.0001 (IECEX)

Russian (GOST R)

Accessories

	CODE
2.5mm-thick stainless steel internal mounting plate:	B30-443
Terminal block mounting rails:	OBO2060/S
Breather and drain valve:	ECD-210S

Other:

Padlocking system

Internal anti-condensation coating

External epoxy coatings in different colour

Terminals

Clip for grouping cables in single bundle

M6 or M8 through earth connection

Plugs, cable glands, adapters, sealed bushings

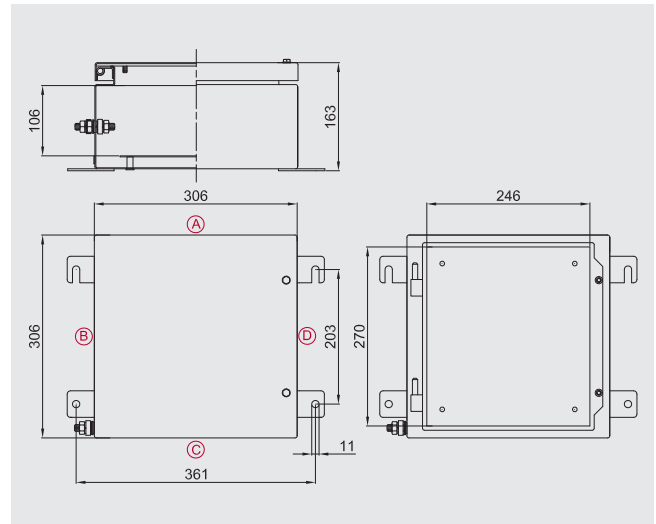

Ordering details for boxes with removable gland plates

Removable gland plate position coding

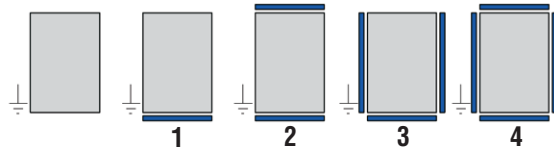

Ordering code examples

1) CTB503516S3

500x350x160 stainless steel box with 3 removable gland plates

2) CTB624520S4

620x450x205 stainless steel box with 4 removable gland plates

Max. number of terminals

X-SECT.	QTY.
1.5 mm ²	2x54
2.5 mm ²	2x37
4 mm ²	2x31
6 mm ²	2x23
10 mm ²	2x18
16 mm ²	2x15
25 mm ²	11



Eg. 2x22= 2 rows of 22 terminals (total 44 terminals). The maximum number of standard terminals refers to the mounting of CABUR and/or WEIDMULLER terminals.

The data in the table are given as a rough guide only based solely on the size of the enclosures and the space taken up by the terminals.

Number of cable glands

Standard enclosure			With removable gland plates		
Hole type	A/C	B/D	Hole type	A/C	B/D
M20	12	12	M20	12	10
M25	10	10	M25	10	8
M32	9	9	M32	4	4
M40	8	8	M40	4	3
M50	3	3	M50	3	3
M63	2	2	M63	2	2



Research conducted using Cortem's new REV and REVD series cable glands.

As required by the current standard, holes can be drilled by Cortem or by authorized partners who hold a production notification in accordance with ATEX Directive 94/9/EC.

CTB... series (Ex e) and (Ex i) stainless steel junction boxes

Ex e

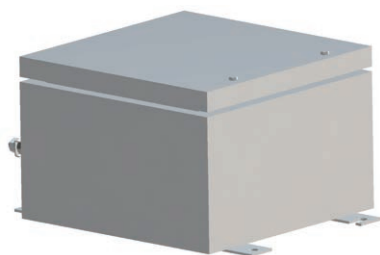

Zone 1,2,21,22.
Degree of protection IP66.
Stainless steel body and lid.
Acid/hydrocarbon-resistant gasket.
Stainless steel bolts and screws.
Impact protection IK10.

Ordering details

Standard stainless steel enclosure:	CTB303020
Width/Depth/Height:	306/306/205mm

Certification data for enclosures with terminals

Group II Category 2GD
Zone 1 - Zone 2 (Gas) Zone 21 - Zone 22 (Dust)
II 2GD Ex e IIC T.. Gb - Ex tb IIIC T.. Db IP66
II 2GD Ex ia IIC T.. Gb - Ex ia IIIC T.. Db IP66
II 2GD Ex e ia IIC T.. Gb - Ex tb ia IIIC T.. Db IP66
Ambient temperature: -40°C +55°C (+40°C)

Certification:

CESI 03 ATEX 333 (ATEX)
IEC Ex CES 13.0001 (IECEX)
Russian (GOST R)

Accessories

	CODE
2.5mm-thick stainless steel internal mounting plate:	B30-443
Terminal block mounting rails:	OBO2060/S
Breather and drain valve:	ECD-210S

Other:

Padlocking system
Internal anti-condensation coating
External epoxy coatings in different colour
Terminals
Clip for grouping cables in single bundle
M6 or M8 through earth connection
Plugs, cable glands, adapters, sealed bushings

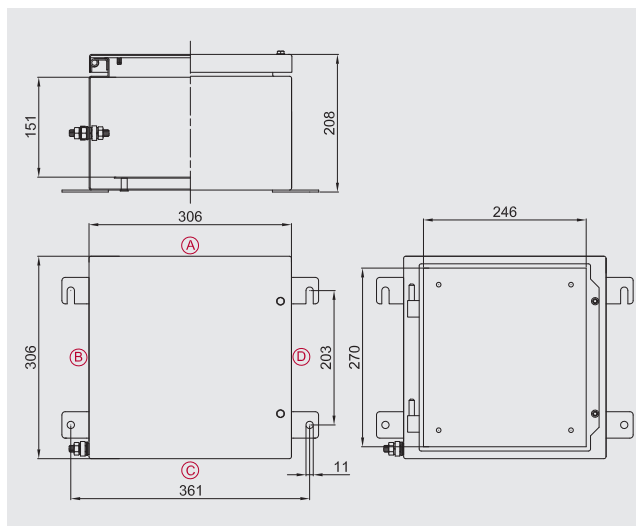

Ordering details for boxes with removable gland plates

Removable gland plate position coding

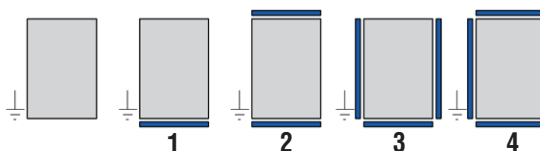

Ordering code examples

- CTB503516S3**
500x350x160 stainless steel box with 3 removable gland plates
- CTB624520S4**
620x450x205 stainless steel box with 4 removable gland plates

Max. number of terminals

X-SECT.	QTY.
2.5 mm ²	2x37
4 mm ²	2x31
6 mm ²	2x23
10 mm ²	2x18
16 mm ²	2x15
25 mm ²	11
35 mm ²	11
50 mm ²	10
70 mm ²	9



Eg. 2x22= 2 rows of 22 terminals (total 44 terminals). The maximum number of standard terminals refers to the mounting of CABUR and/or WEIDMULLER terminals.
The data in the table are given as a rough guide only based solely on the size of the enclosures and the space taken up by the terminals.

Number of cable glands

Standard enclosure			With removable gland plates		
Hole type	A/C	B/D	Hole type	A/C	B/D
M20	18	18	M20	18	15
M25	17	15	M25	13	10
M32	10	10	M32	8	8
M40	8	8	M40	4	3
M50	6	6	M50	3	2
M63	3	3			



Research conducted using Cortem's new REV and REVD series cable glands.

As required by the current standard, holes can be drilled by Cortem or by authorized partners who hold a production notification in accordance with ATEX Directive 94/9/EC.

CTB... series (Ex e) and (Ex i) stainless steel junction boxes

Ex e

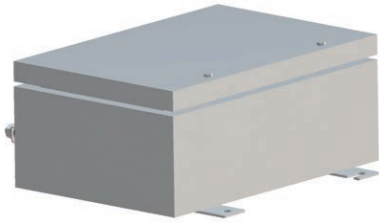

Zone 1,2,21,22.
Degree of protection IP66.
Stainless steel body and lid.
Acid/hydrocarbon-resistant gasket.
Stainless steel bolts and screws.
Impact protection IK10.

Ordering details

Standard stainless steel enclosure: **CTB382616**

Width/Depth/Height: **380/260/160mm**

Certification data for enclosures with terminals

Group II Category 2GD

Zone 1- Zone 2 (Gas) Zone 21 - Zone 22 (Dust)

II 2GD Ex e IIC T.. Gb - Ex tb IIIC T.. Db IP66

II 2GD Ex ia IIC T.. Gb - Ex ia IIIC T.. Db IP66

II 2GD Ex e ia IIC T.. Gb - Ex tb ia IIIC T.. Db IP66

Ambient temperature: -40°C +55°C (+40°C)

Certification:

CESI 03 ATEX 333 (ATEX)

IEC Ex CES 13.0001 (IECEX)

Russian (GOST R)

Accessories

	CODE
2.5mm-thick stainless steel internal mounting plate:	B38-443
Terminal block mounting rails:	OBO2060/S
Breather and drain valve:	ECD-210S

Other:

Padlocking system

Internal anti-condensation coating

External epoxy coatings in different colour

Terminals

Clip for grouping cables in single bundle

M6 or M8 through earth connection

Plugs, cable glands, adapters, sealed bushings

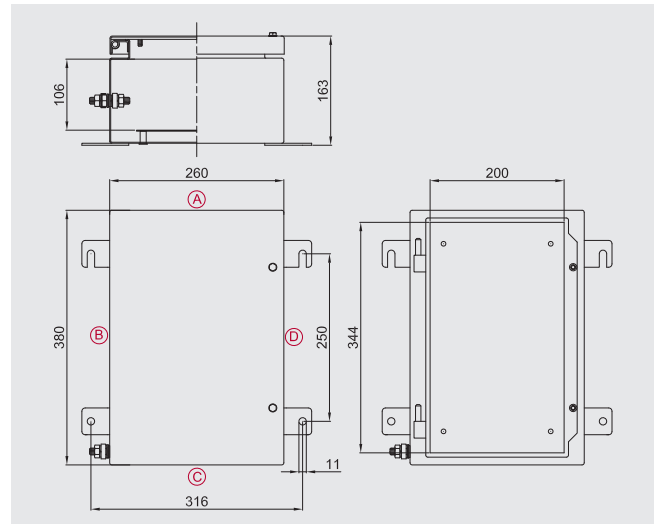

Ordering details for boxes with removable gland plates

Removable gland plate position coding

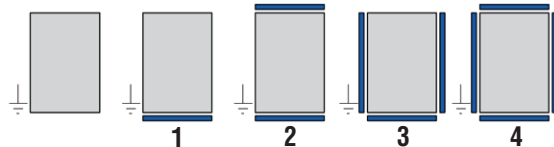

Ordering code examples

1) CTB503516S3

500x350x160 stainless steel box with 3 removable gland plates

2) CTB624520S4

620x450x205 stainless steel box with 4 removable gland plates

Max. number of terminals

X-SECT.	QTY.
2.5 mm ²	2x71
4 mm ²	2x49
6 mm ²	2x41
10 mm ²	2x31
16 mm ²	2x20
25 mm ²	15
35 mm ²	15
50 mm ²	13
70 mm ²	11



Eg. 2x22= 2 rows of 22 terminals (total 44 terminals). The maximum number of standard terminals refers to the mounting of CABUR and/or WEIDMULLER terminals.

The data in the table are given as a rough guide only based solely on the size of the enclosures and the space taken up by the terminals.

Number of cable glands

Standard enclosure			With removable gland plates		
Hole type	A/C	B/D	Hole type	A/C	B/D
M20	10	16	M20	10	12
M25	10	14	M25	8	9
M32	7	11	M32	4	4
M40	3	5	M40	3	3
M50	2	4	M50	3	3
M63	2	3			



Research conducted using Cortem's new REV and REVD series cable glands.

As required by the current standard, holes can be drilled by Cortem or by authorized partners who hold a production notification in accordance with ATEX Directive 94/9/EC.

CTB... series (Ex e) and (Ex i) stainless steel junction boxes

Ex e

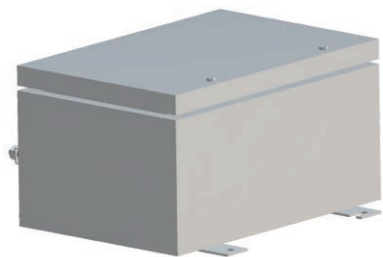

Zone 1,2,21,22.
Degree of protection IP66.
Stainless steel body and lid.
Acid/hydrocarbon-resistant gasket.
Stainless steel bolts and screws.
Impact protection IK10.

Ordering details

Standard stainless steel enclosure:	CTB382620
Width/Depth/Height:	380/260/205mm

Certification data for enclosures with terminals

Group II Category 2GD
Zone 1 - Zone 2 (Gas) Zone 21 - Zone 22 (Dust)
II 2GD Ex e IIC T.. Gb - Ex tb IIIC T.. Db IP66
II 2GD Ex ia IIC T.. Gb - Ex ia IIIC T.. Db IP66
II 2GD Ex e ia IIC T.. Gb - Ex tb ia IIIC T.. Db IP66
Ambient temperature: -40°C +55°C (+40°C)

Certification:

CESI 03 ATEX 333 (ATEX)
IEC Ex CES 13.0001 (IECEX)
Russian (GOST R)

Accessories

	CODE
2.5mm-thick stainless steel internal mounting plate:	B38-443
Terminal block mounting rails:	OBO2060/S
Breather and drain valve:	ECD-210S

Other:

Padlocking system
Internal anti-condensation coating
External epoxy coatings in different colour
Terminals
Clip for grouping cables in single bundle
M6 or M8 through earth connection
Plugs, cable glands, adapters, sealed bushings

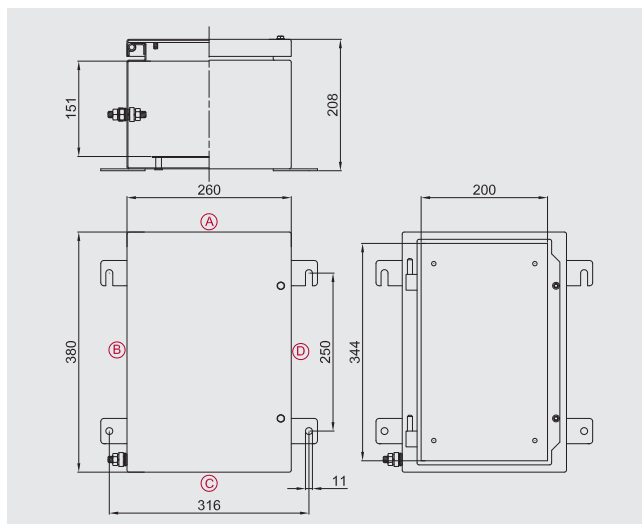

Ordering details for boxes with removable gland plates

Removable gland plate position coding

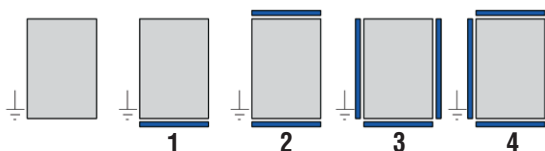

Ordering code examples

- CTB503516S3**
500x350x160 stainless steel box with 3 removable gland plates
- CTB624520S4**
620x450x205 stainless steel box with 4 removable gland plates

Max. number of terminals

X-SECT.	QTY.
2.5 mm ²	2x65
4 mm ²	2x54
6 mm ²	2x41
10 mm ²	2x32
16 mm ²	2x27
25 mm ²	2x20
35 mm ²	2x20
50 mm ²	2x18
70 mm ²	2x15



Eg. 2x22= 2 rows of 22 terminals (total 44 terminals). The maximum number of standard terminals refers to the mounting of CABUR and/or WEIDMULLER terminals.
The data in the table are given as a rough guide only based solely on the size of the enclosures and the space taken up by the terminals.

Number of cable glands

Standard enclosure			With removable gland plates		
Hole type	A/C	B/D	Hole type	A/C	B/D
M20	15	24	M20	15	18
M25	12	21	M25	12	15
M32	8	12	M32	8	8
M40	6	10	M40	6	5
M50	6	8	M50	4	3
M63	2	3			



Research conducted using Cortem's new REV and REVD series cable glands.

As required by the current standard, holes can be drilled by Cortem or by authorized partners who hold a production notification in accordance with ATEX Directive 94/9/EC.

CTB... series (Ex e) and (Ex i) stainless steel junction boxes

Ex e

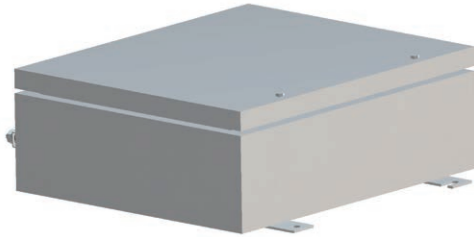

Zone 1,2,21,22.
Degree of protection IP66.
Stainless steel body and lid.
Acid/hydrocarbon-resistant gasket.
Stainless steel bolts and screws.
Impact protection IK10.

Ordering details

Standard stainless steel enclosure: **CTB453816**

Width/Depth/Height: **450/380/160mm**

Certification data for enclosures with terminals

Group II Category 2GD

Zone 1- Zone 2 (Gas) Zone 21 - Zone 22 (Dust)

II 2GD Ex e IIC T.. Gb - Ex tb IIIC T.. Db IP66

II 2GD Ex ia IIC T.. Gb - Ex ia IIIC T.. Db IP66

II 2GD Ex e ia IIC T.. Gb - Ex tb ia IIIC T.. Db IP66

Ambient temperature: -40°C +55°C (+40°C)

Certification:

CESI 03 ATEX 333 (ATEX)

IEC Ex CES 13.0001 (IECEX)

Russian (GOST R)

Accessories

	CODE
2.5mm-thick stainless steel internal mounting plate:	B45-443
Terminal block mounting rails:	OBO2060/S
Breather and drain valve:	ECD-210S

Other:

Padlocking system

Internal anti-condensation coating

External epoxy coatings in different colour

Terminals

Clip for grouping cables in single bundle

M6 or M8 through earth connection

Plugs, cable glands, adapters, sealed bushings

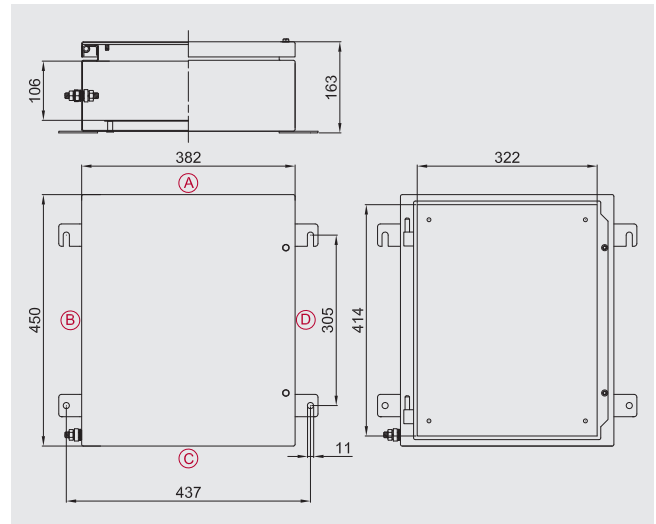

Ordering details for boxes with removable gland plates

Removable gland plate position coding

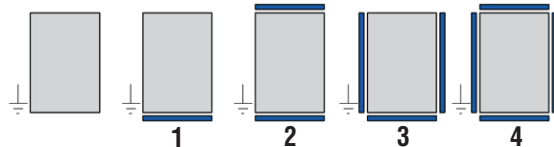

Ordering code examples

1) CTB503516S3

500x350x160 stainless steel box with 3 removable gland plates

2) CTB624520S4

620x450x205 stainless steel box with 4 removable gland plates

Max. number of terminals

X-SECT.	QTY.
2.5 mm ²	2x65
4 mm ²	2x54
6 mm ²	2x41
10 mm ²	2x32
16 mm ²	2x27
25 mm ²	2x20
35 mm ²	2x20
50 mm ²	2x17
70 mm ²	2x15



Eg. 2x22= 2 rows of 22 terminals (total 44 terminals). The maximum number of standard terminals refers to the mounting of CABUR and/or WEIDMULLER terminals.

The data in the table are given as a rough guide only based solely on the size of the enclosures and the space taken up by the terminals.

Number of cable glands

Standard enclosure			With removable gland plates		
Hole type	A/C	B/D	Hole type	A/C	B/D
M20	16	20	M20	16	16
M25	14	16	M25	14	14
M32	6	7	M32	6	6
M40	5	6	M40	5	5
M50	4	5	M50	4	4
M63	3	4	M63	3	3



Research conducted using Cortem's new REV and REVD series cable glands.

As required by the current standard, holes can be drilled by Cortem or by authorized partners who hold a production notification in accordance with ATEX Directive 94/9/EC.

CTB... series (Ex e) and (Ex i) stainless steel junction boxes

Ex e

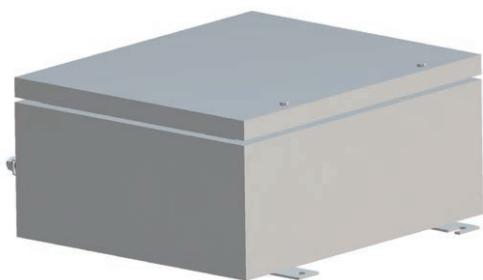

Zone 1,2,21,22.
Degree of protection IP66.
Stainless steel body and lid.
Acid/hydrocarbon-resistant gasket.
Stainless steel bolts and screws.
Impact protection IK10.

Ordering details

Standard stainless steel enclosure:	CTB453820
Width/Depth/Height:	450/380/205mm

Certification data for enclosures with terminals

Group II Category 2GD
Zone 1 - Zone 2 (Gas) Zone 21 - Zone 22 (Dust)
II 2GD Ex e IIC T.. Gb - Ex tb IIIC T.. Db IP66
II 2GD Ex ia IIC T.. Gb - Ex ia IIIC T.. Db IP66
II 2GD Ex e ia IIC T.. Gb - Ex tb ia IIIC T.. Db IP66
Ambient temperature: -40°C +55°C (+40°C)

Certification:

CESI 03 ATEX 333 (ATEX)
IEC Ex CES 13.0001 (IECEX)
Russian (GOST R)

Accessories

	CODE
2.5mm-thick stainless steel internal mounting plate:	B45-443
Terminal block mounting rails:	OBO2060/S
Breather and drain valve:	ECD-210S

Other:

Padlocking system
Internal anti-condensation coating
External epoxy coatings in different colour
Terminals
Clip for grouping cables in single bundle
M6 or M8 through earth connection
Plugs, cable glands, adapters, sealed bushings

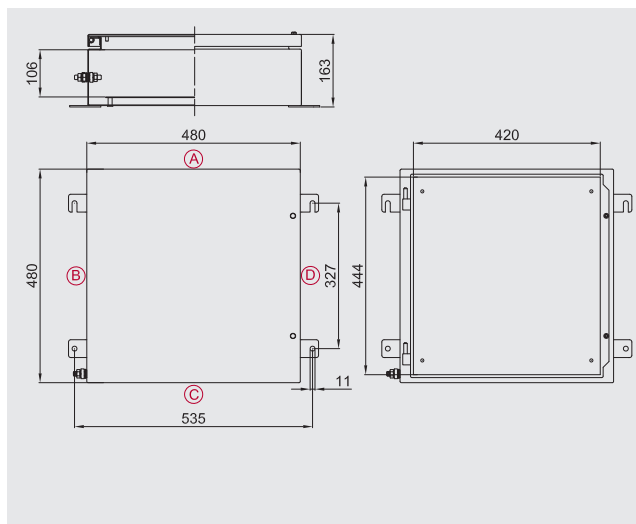

Ordering details for boxes with removable gland plates

Removable gland plate position coding

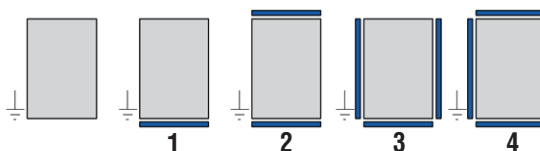

Ordering code examples

- CTB503516S3**
500x350x160 stainless steel box with 3 removable gland plates
- CTB624520S4**
620x450x205 stainless steel box with 4 removable gland plates

Max. number of terminals

X-SECT.	QTY.
2.5 mm ²	2x65
4 mm ²	2x54
6 mm ²	2x41
10 mm ²	2x32
16 mm ²	2x27
25 mm ²	2x20
70 mm ²	2x15
185 mm ²	8
300 mm ²	6



Eg. 2x22= 2 rows of 22 terminals (total 44 terminals). The maximum number of standard terminals refers to the mounting of CABUR and/or WEIDMULLER terminals.
The data in the table are given as a rough guide only based solely on the size of the enclosures and the space taken up by the terminals.

Number of cable glands

Standard enclosure			With removable gland plates		
Hole type	A/C	B/D	Hole type	A/C	B/D
M20	24	30	M20	24	24
M25	21	24	M25	20	20
M32	12	14	M32	12	12
M40	10	12	M40	8	8
M50	8	10	M50	4	4
M63	3	4	M63	3	3



Research conducted using Cortem's new REV and REVD series cable glands.

As required by the current standard, holes can be drilled by Cortem or by authorized partners who hold a production notification in accordance with ATEX Directive 94/9/EC.

CTB... series (Ex e) and (Ex i) stainless steel junction boxes

Ex e

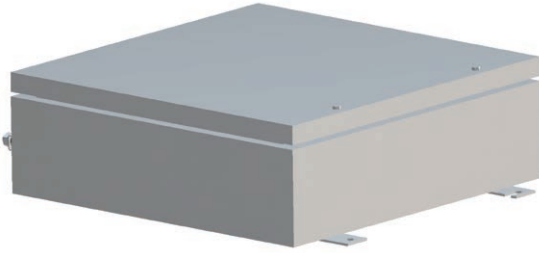

Zone 1,2,21,22.
Degree of protection IP66.
Stainless steel body and lid.
Acid/hydrocarbon-resistant gasket.
Stainless steel bolts and screws.
Impact protection IK10.

Ordering details

Standard stainless steel enclosure: **CTB484816**

Width/Depth/Height: **480/480/160mm**

Certification data for enclosures with terminals

Group II Category 2GD

Zone 1 - Zone 2 (Gas) Zone 21 - Zone 22 (Dust)

II 2GD Ex e IIC T.. Gb - Ex tb IIIC T.. Db IP66

II 2GD Ex ia IIC T.. Gb - Ex ia IIIC T.. Db IP66

II 2GD Ex e ia IIC T.. Gb - Ex tb ia IIIC T.. Db IP66

Ambient temperature: -40°C +55°C (+40°C)

Certification:

CESI 03 ATEX 333 (ATEX)

IEC Ex CES 13.0001 (IECEX)

Russian (GOST R)

Accessories

	CODE
2.5mm-thick stainless steel internal mounting plate:	B48-443
Terminal block mounting rails:	OBO2060/S
Breather and drain valve:	ECD-210S

Other:

Padlocking system

Internal anti-condensation coating

External epoxy coatings in different colour

Terminals

Clip for grouping cables in single bundle

M6 or M8 through earth connection

Plugs, cable glands, adapters, sealed bushings

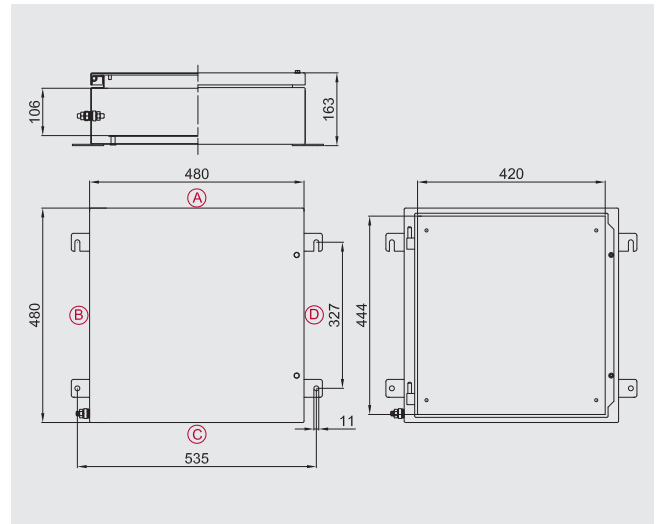

Ordering details for boxes with removable gland plates

Removable gland plate position coding

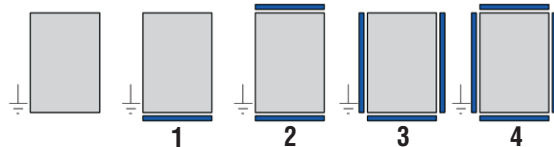

Ordering code examples

1) CTB503516S3

500x350x160 stainless steel box with 3 removable gland plates

2) CTB624520S4

620x450x205 stainless steel box with 4 removable gland plates

Max. number of terminals

X-SECT.	QTY.
2.5 mm ²	3x69
4 mm ²	3x58
6 mm ²	3x43
10 mm ²	2x34
16 mm ²	2x28
25 mm ²	2x21
35 mm ²	2x21
50 mm ²	2x18
70 mm ²	2x16



Eg. 2x22= 2 rows of 22 terminals (total 44 terminals). The maximum number of standard terminals refers to the mounting of CABUR and/or WEIDMULLER terminals.

The data in the table are given as a rough guide only based solely on the size of the enclosures and the space taken up by the terminals.

Number of cable glands

Standard enclosure			With removable gland plates		
Hole type	A/C	B/D	Hole type	A/C	B/D
M20	22	20	M20	22	18
M25	18	18	M25	18	14
M32	8	8	M32	7	6
M40	7	6	M40	5	5
M50	6	5	M50	5	4
M63	4	4	M63	4	3



Research conducted using Cortem's new REV and REVD series cable glands.

As required by the current standard, holes can be drilled by Cortem or by authorized partners who hold a production notification in accordance with ATEX Directive 94/9/EC.

CTB... series (Ex e) and (Ex i) stainless steel junction boxes

Ex e

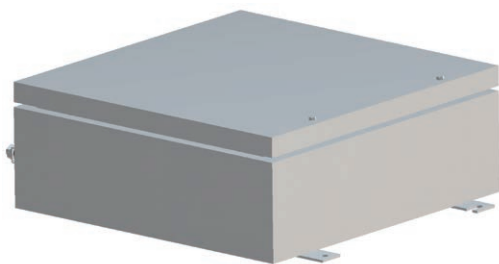

Zone 1,2,21,22.
Degree of protection IP66.
Stainless steel body and lid.
Acid/hydrocarbon-resistant gasket.
Stainless steel bolts and screws.
Impact protection IK10.

Ordering details

Standard stainless steel enclosure:	CTB484820
Width/Depth/Height:	480/480/205mm

Certification data for enclosures with terminals

Group II Category 2GD
Zone 1 - Zone 2 (Gas) Zone 21 - Zone 22 (Dust)
II 2GD Ex e IIC T.. Gb - Ex tb IIIC T.. Db IP66
II 2GD Ex ia IIC T.. Gb - Ex ia IIIC T.. Db IP66
II 2GD Ex e ia IIC T.. Gb - Ex tb ia IIIC T.. Db IP66
Ambient temperature: -40°C +55°C (+40°C)

Certification:

CESI 03 ATEX 333 (ATEX)
IEC Ex CES 13.0001 (IECEX)
Russian (GOST R)

Accessories

	CODE
2.5mm-thick stainless steel internal mounting plate:	B48-443
Terminal block mounting rails:	OBO2060/S
Breather and drain valve:	ECD-210S

Other:

Padlocking system
Internal anti-condensation coating
External epoxy coatings in different colour
Terminals
Clip for grouping cables in single bundle
M6 or M8 through earth connection
Plugs, cable glands, adapters, sealed bushings

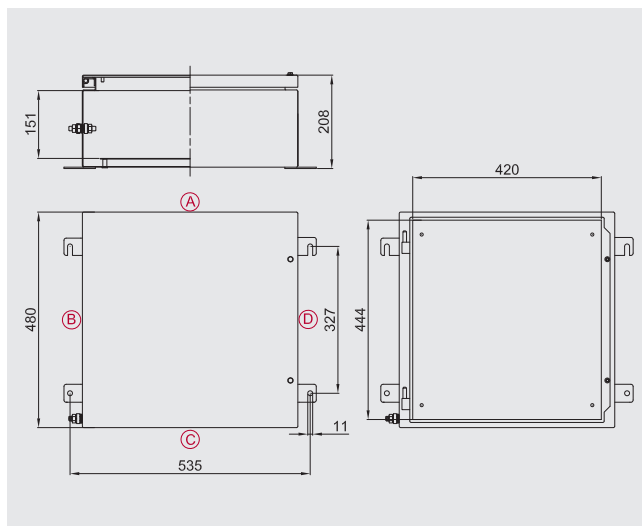

Ordering details for boxes with removable gland plates

Removable gland plate position coding

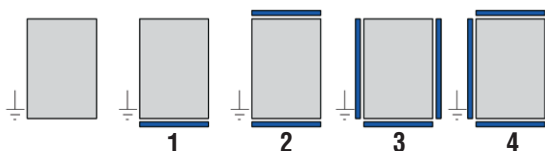

Ordering code examples

- CTB503516S3**
500x350x160 stainless steel box with 3 removable gland plates
- CTB624520S4**
620x450x205 stainless steel box with 4 removable gland plates

Max. number of terminals

X-SECT.	QTY.
2.5 mm ²	3x69
4 mm ²	3x58
6 mm ²	3x43
10 mm ²	2x34
16 mm ²	2x28
25 mm ²	2x21
70 mm ²	2x16
185 mm ²	9
300 mm ²	6



Eg. 2x22= 2 rows of 22 terminals (total 44 terminals). The maximum number of standard terminals refers to the mounting of CABUR and/or WEIDMULLER terminals.
The data in the table are given as a rough guide only based solely on the size of the enclosures and the space taken up by the terminals.

Number of cable glands

Standard enclosure			With removable gland plates		
Hole type	A/C	B/D	Hole type	A/C	B/D
M20	32	30	M20	32	27
M25	26	26	M25	24	21
M32	16	14	M32	14	12
M40	13	12	M40	12	8
M50	11	10	M50	5	4
M63	4	4	M63	4	3



Research conducted using Cortem's new REV and REVD series cable glands.

As required by the current standard, holes can be drilled by Cortem or by authorized partners who hold a production notification in accordance with ATEX Directive 94/9/EC.

CTB... series (Ex e) and (Ex i) stainless steel junction boxes

Ex e

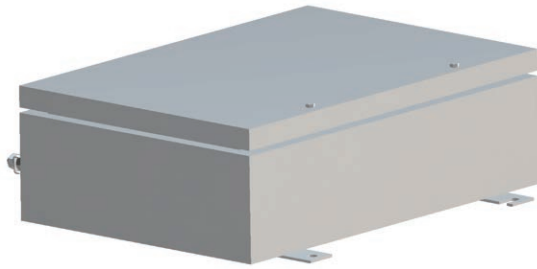

Zone 1,2,21,22.
Degree of protection IP66.
Stainless steel body and lid.
Acid/hydrocarbon-resistant gasket.
Stainless steel bolts and screws.
Impact protection IK10.

Ordering details

Standard stainless steel enclosure: **CTB503516**

Width/Depth/Height: **500/350/160mm**

Certification data for enclosures with terminals

Group II Category 2GD

Zone 1 - Zone 2 (Gas) Zone 21 - Zone 22 (Dust)

II 2GD Ex e IIC T.. Gb - Ex tb IIIC T.. Db IP66

II 2GD Ex ia IIC T.. Gb - Ex ia IIIC T.. Db IP66

II 2GD Ex e ia IIC T.. Gb - Ex tb ia IIIC T.. Db IP66

Ambient temperature: -40°C +55°C (+40°C)

Certification:

CESI 03 ATEX 333 (ATEX)

IEC Ex CES 13.0001 (IECEX)

Russian (GOST R)

Accessories

	CODE
2.5mm-thick stainless steel internal mounting plate:	B50-443
Terminal block mounting rails:	OBO2060/S
Breather and drain valve:	ECD-210S

Other:

Padlocking system

Internal anti-condensation coating

External epoxy coatings in different colour

Terminals

Clip for grouping cables in single bundle

M6 or M8 through earth connection

Plugs, cable glands, adapters, sealed bushings

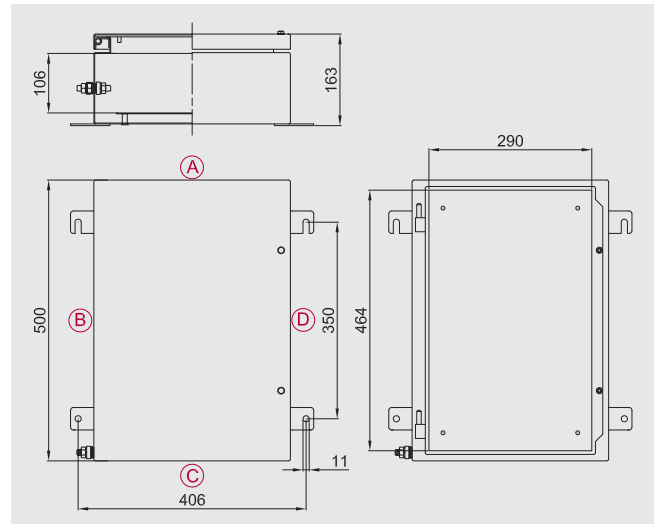

Ordering details for boxes with removable gland plates

Removable gland plate position coding

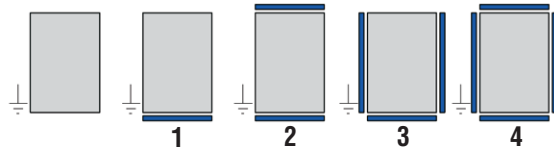

Ordering code examples

1) CTB503516S3

500x350x160 stainless steel box with 3 removable gland plates

2) CTB624520S4

620x450x205 stainless steel box with 4 removable gland plates

Max. number of terminals

X-SECT.	QTY.
2.5 mm ²	2x73
4 mm ²	2x61
6 mm ²	2x46
10 mm ²	2x36
16 mm ²	2x30
25 mm ²	2x22
35 mm ²	2x22
50 mm ²	2x19
70 mm ²	2x17



Eg. 2x22= 2 rows of 22 terminals (total 44 terminals). The maximum number of standard terminals refers to the mounting of CABUR and/or WEIDMULLER terminals.

The data in the table are given as a rough guide only based solely on the size of the enclosures and the space taken up by the terminals.

Number of cable glands

Standard enclosure			With removable gland plates		
Hole type	A/C	B/D	Hole type	A/C	B/D
M20	14	22	M20	14	16
M25	12	19	M25	12	12
M32	5	8	M32	5	5
M40	4	7	M40	4	4
M50	4	6	M50	4	4
M63	3	4	M63	3	3



Research conducted using Cortem's new REV and REVD series cable glands.

As required by the current standard, holes can be drilled by Cortem or by authorized partners who hold a production notification in accordance with ATEX Directive 94/9/EC.

CTB... series (Ex e) and (Ex i) stainless steel junction boxes

Ex e

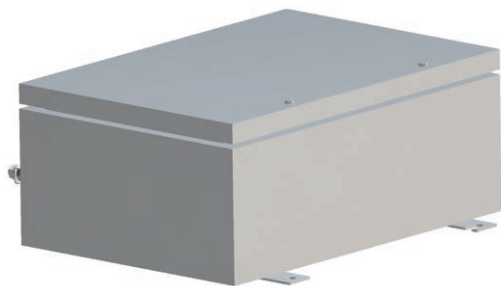

Zone 1,2,21,22.
Degree of protection IP66.
Stainless steel body and lid.
Acid/hydrocarbon-resistant gasket.
Stainless steel bolts and screws.
Impact protection IK10.

Ordering details

Standard stainless steel enclosure:	CTB503520
Width/Depth/Height:	500/350/205mm

Certification data for enclosures with terminals

Group II Category 2GD
Zone 1 - Zone 2 (Gas) Zone 21 - Zone 22 (Dust)
II 2GD Ex e IIC T.. Gb - Ex tb IIIC T.. Db IP66
II 2GD Ex ia IIC T.. Gb - Ex ia IIIC T.. Db IP66
II 2GD Ex e ia IIC T.. Gb - Ex tb ia IIIC T.. Db IP66
Ambient temperature: -40°C +55°C (+40°C)

Certification:

CESI 03 ATEX 333 (ATEX)
IEC Ex CES 13.0001 (IECEX)
Russian (GOST R)

Accessories

	CODE
2.5mm-thick stainless steel internal mounting plate:	B50-443
Terminal block mounting rails:	OBO2060/S
Breather and drain valve:	ECD-210S

Other:

Padlocking system
Internal anti-condensation coating
External epoxy coatings in different colour
Terminals
Clip for grouping cables in single bundle
M6 or M8 through earth connection
Plugs, cable glands, adapters, sealed bushings

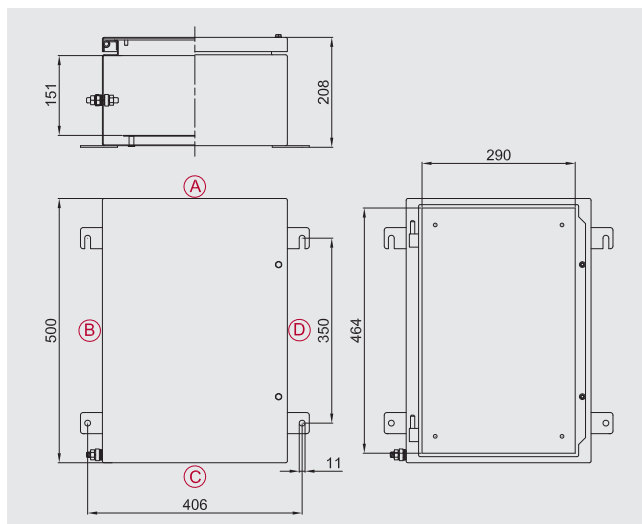

Ordering details for boxes with removable gland plates

Removable gland plate position coding

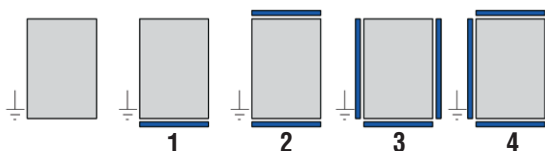

Ordering code examples

- CTB503516S3**
500x350x160 stainless steel box with 3 removable gland plates
- CTB624520S4**
620x450x205 stainless steel box with 4 removable gland plates

Max. number of terminals

X-SECT.	QTY.
2.5 mm ²	2x73
4 mm ²	2x61
6 mm ²	2x46
10 mm ²	2x36
16 mm ²	2x30
25 mm ²	2x22
70 mm ²	2x17
185 mm ²	10
300 mm ²	6



Eg. 2x22= 2 rows of 22 terminals (total 44 terminals). The maximum number of standard terminals refers to the mounting of CABUR and/or WEIDMULLER terminals.
The data in the table are given as a rough guide only based solely on the size of the enclosures and the space taken up by the terminals.

Number of cable glands

Standard enclosure			With removable gland plates		
Hole type	A/C	B/D	Hole type	A/C	B/D
M20	21	33	M20	21	24
M25	18	27	M25	17	18
M32	12	16	M32	10	10
M40	10	14	M40	8	8
M50	7	11	M50	4	4
M63	3	4	M63	3	3



Research conducted using Cortem's new REV and REVD series cable glands.

As required by the current standard, holes can be drilled by Cortem or by authorized partners who hold a production notification in accordance with ATEX Directive 94/9/EC.

CTB... series (Ex e) and (Ex i) stainless steel junction boxes

Ex e

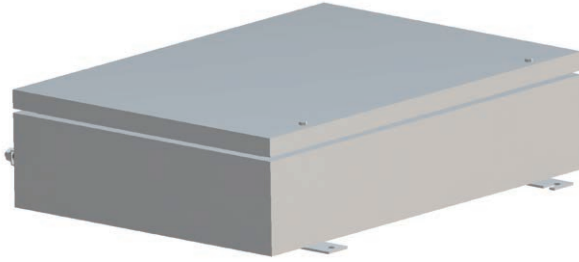

Zone 1,2,21,22.
Degree of protection IP66.
Stainless steel body and lid.
Acid/hydrocarbon-resistant gasket.
Stainless steel bolts and screws.
Impact protection IK10.

Ordering details

Standard stainless steel enclosure: **CTB624516**

Width/Depth/Height: **620/450/160mm**

Certification data for enclosures with terminals

Group II Category 2GD

Zone 1- Zone 2 (Gas) Zone 21 - Zone 22 (Dust)

II 2GD Ex e IIC T.. Gb - Ex tb IIIC T.. Db IP66

II 2GD Ex ia IIC T.. Gb - Ex ia IIIC T.. Db IP66

II 2GD Ex e ia IIC T.. Gb - Ex tb ia IIIC T.. Db IP66

Ambient temperature: -40°C +55°C (+40°C)

Certification:

CESI 03 ATEX 333 (ATEX)

IEC Ex CES 13.0001 (IECEX)

Russian (GOST R)

Accessories

	CODE
2.5mm-thick stainless steel internal mounting plate:	B62-443
Terminal block mounting rails:	OBO2060/S
Breather and drain valve:	ECD-210S

Other:

Padlocking system

Internal anti-condensation coating

External epoxy coatings in different colour

Terminals

Clip for grouping cables in single bundle

M6 or M8 through earth connection

Plugs, cable glands, adapters, sealed bushings

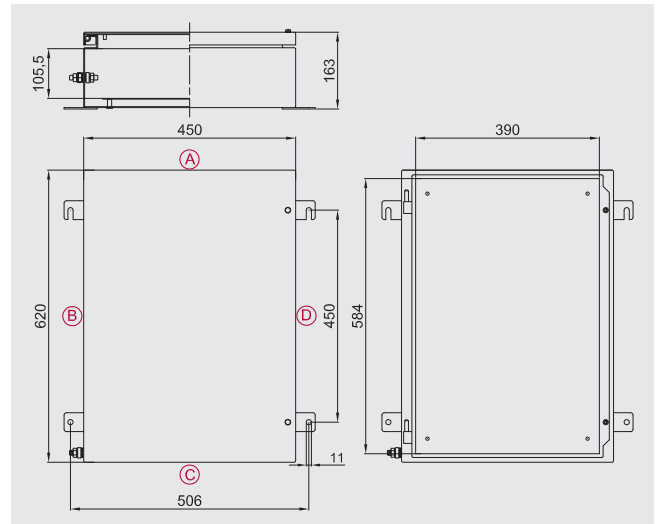

Ordering details for boxes with removable gland plates

Removable gland plate position coding

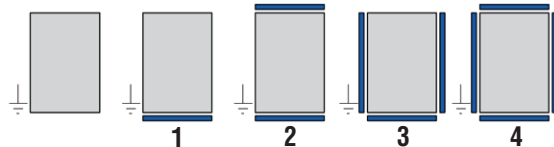

Ordering code examples

1) CTB503516S3

500x350x160 stainless steel box with 3 removable gland plates

2) CTB624520S4

620x450x205 stainless steel box with 4 removable gland plates

Max. number of terminals

X-SECT.	QTY.
2.5 mm ²	3x97
4 mm ²	3x81
6 mm ²	3x61
10 mm ²	2x48
16 mm ²	2x40
25 mm ²	2x30
35 mm ²	2x30
50 mm ²	2x26
70 mm ²	2x23



Eg. 2x22= 2 rows of 22 terminals (total 44 terminals). The maximum number of standard terminals refers to the mounting of CABUR and/or WEIDMULLER terminals.

The data in the table are given as a rough guide only based solely on the size of the enclosures and the space taken up by the terminals.

Number of cable glands

Standard enclosure			With removable gland plates		
Hole type	A/C	B/D	Hole type	A/C	B/D
M20	20	28	M20	19	22
M25	18	24	M25	16	16
M32	7	10	M32	7	7
M40	6	9	M40	6	6
M50	5	7	M50	5	5
M63	4	6	M63	4	4



Research conducted using Cortem's new REV and REVD series cable glands.

As required by the current standard, holes can be drilled by Cortem or by authorized partners who hold a production notification in accordance with ATEX Directive 94/9/EC.

CTB... series (Ex e) and (Ex i) stainless steel junction boxes

Ex e

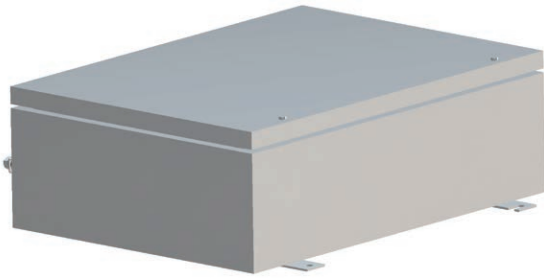

Zone 1,2,21,22.
Degree of protection IP66.
Stainless steel body and lid.
Acid/hydrocarbon-resistant gasket.
Stainless steel bolts and screws.
Impact protection IK10.

Ordering details

Standard stainless steel enclosure: **CTB624520**

Width/Depth/Height: **620/450/205mm**

Certification data for enclosures with terminals

Group II Category 2GD

Zone 1 - Zone 2 (Gas) Zone 21 - Zone 22 (Dust)

II 2GD Ex e IIC T.. Gb - Ex tb IIIC T.. Db IP66

II 2GD Ex ia IIC T.. Gb - Ex ia IIIC T.. Db IP66

II 2GD Ex e ia IIC T.. Gb - Ex tb ia IIIC T.. Db IP66

Ambient temperature: -40°C +55°C (+40°C)

Certification:

CESI 03 ATEX 333 (ATEX)

IEC Ex CES 13.0001 (IECEX)

Russian (GOST R)

Accessories

	CODE
2.5mm-thick stainless steel internal mounting plate:	B62-443
Terminal block mounting rails:	OBO2060/S
Breather and drain valve:	ECD-210S

Other:

Padlocking system

Internal anti-condensation coating

External epoxy coatings in different colour

Terminals

Clip for grouping cables in single bundle

M6 or M8 through earth connection

Plugs, cable glands, adapters, sealed bushings

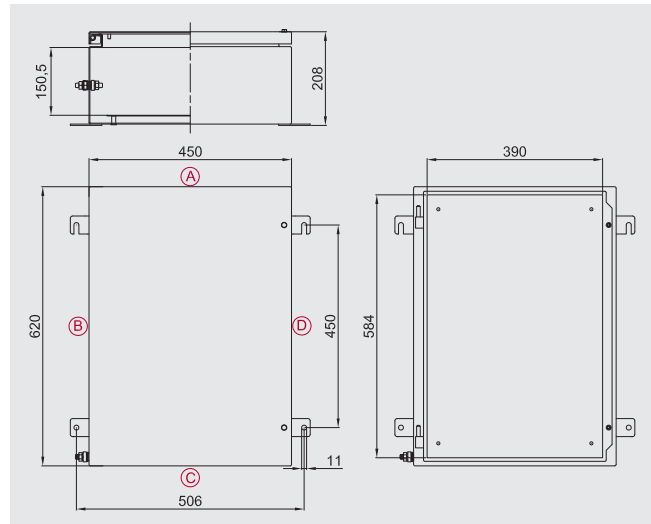

Ordering details for boxes with removable gland plates

Removable gland plate position coding

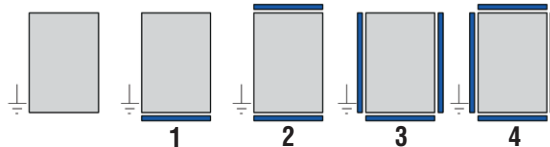

Ordering code examples

1) CTB503516S3

500x350x160 stainless steel box with 3 removable gland plates

2) CTB624520S4

620x450x205 stainless steel box with 4 removable gland plates

Max. number of terminals

X-SECT.	QTY.
2.5 mm ²	3x97
4 mm ²	3x81
6 mm ²	3x61
10 mm ²	2x48
16 mm ²	2x40
25 mm ²	2x30
70 mm ²	2x23
185 mm ²	13
300 mm ²	9



Eg. 2x22= 2 rows of 22 terminals (total 44 terminals). The maximum number of standard terminals refers to the mounting of CABUR and/or WEIDMULLER terminals.

The data in the table are given as a rough guide only based solely on the size of the enclosures and the space taken up by the terminals.

Number of cable glands

Standard enclosure			With removable gland plates		
Hole type	A/C	B/D	Hole type	A/C	B/D
M20	30	39	M20	29	33
M25	26	36	M25	23	24
M32	14	20	M32	14	14
M40	12	18	M40	10	12
M50	10	15	M50	5	5
M63	4	6	M63	4	4



Research conducted using Cortem's new REV and REVD series cable glands.

As required by the current standard, holes can be drilled by Cortem or by authorized partners who hold a production notification in accordance with ATEX Directive 94/9/EC.

CTB... series (Ex e) and (Ex i) stainless steel junction boxes

Ex e

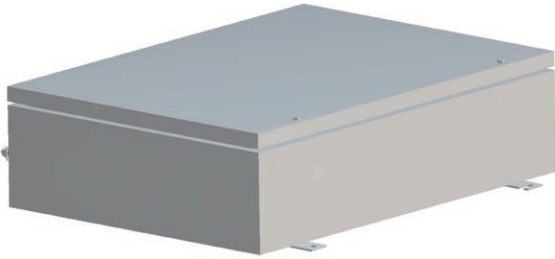

Zone 1,2,21,22.
Degree of protection IP66.
Stainless steel body and lid.
Acid/hydrocarbon-resistant gasket.
Stainless steel bolts and screws.
Impact protection IK10.

Ordering details

Standard stainless steel enclosure: **CTB745520**

Width/Depth/Height: **740/550/205mm**

Certification data for enclosures with terminals

Group II Category 2GD

Zone 1 - Zone 2 (Gas) Zone 21 - Zone 22 (Dust)

II 2GD Ex e IIC T.. Gb - Ex tb IIIC T.. Db IP66

II 2GD Ex ia IIC T.. Gb - Ex ia IIIC T.. Db IP66

II 2GD Ex e ia IIC T.. Gb - Ex tb ia IIIC T.. Db IP66

Ambient temperature: -40°C +55°C (+40°C)

Certification:

CESI 03 ATEX 333 (ATEX)

IEC Ex CES 13.0001 (IECEX)

Russian (GOST R)

Accessories

	CODE
2.5mm-thick stainless steel internal mounting plate:	B74-443
Terminal block mounting rails:	OBO2060/S
Breather and drain valve:	ECD-210S

Other:

Padlocking system

Internal anti-condensation coating

External epoxy coatings in different colour

Terminals

Clip for grouping cables in single bundle

M6 or M8 through earth connection

Plugs, cable glands, adapters, sealed bushings

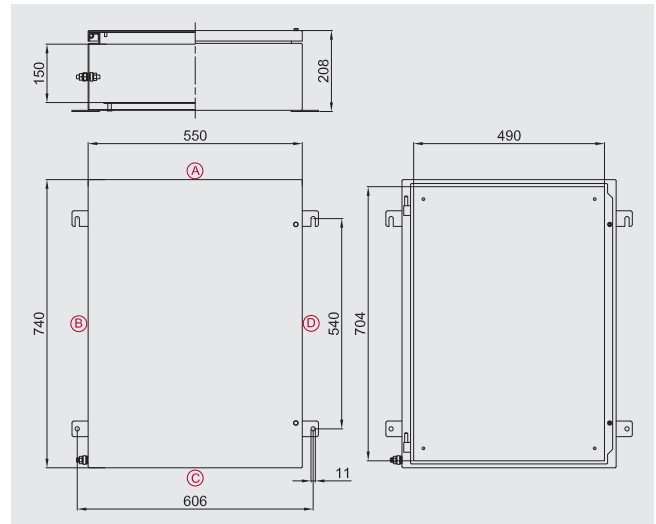

Ordering details for boxes with removable gland plates

Removable gland plate position coding

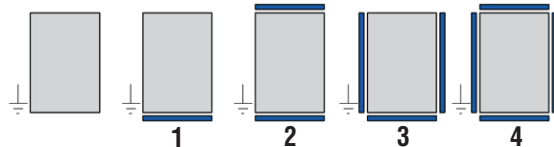

Ordering code examples

1) CTB503516S3

500x350x160 stainless steel box with 3 removable gland plates

2) CTB624520S4

620x450x205 stainless steel box with 4 removable gland plates

Max. number of terminals

X-SECT.	QTY.
2.5 mm ²	4x121
4 mm ²	4x101
6 mm ²	4x76
10 mm ²	3x60
16 mm ²	3x50
25 mm ²	3x37
70 mm ²	3x29
185 mm ²	16
300 mm ²	11



Eg. 2x22= 2 rows of 22 terminals (total 44 terminals). The maximum number of standard terminals refers to the mounting of CABUR and/or WEIDMULLER terminals.

The data in the table are given as a rough guide only based solely on the size of the enclosures and the space taken up by the terminals.

Number of cable glands

Standard enclosure			With removable gland plates		
Hole type	A/C	B/D	Hole type	A/C	B/D
M20	36	50	M20	36	42
M25	32	42	M25	30	30
M32	16	24	M32	16	18
M40	16	21	M40	13	14
M50	13	17	M50	7	7
M63	5	7	M63	5	5



Research conducted using Cortem's new REV and REVD series cable glands.

As required by the current standard, holes can be drilled by Cortem or by authorized partners who hold a production notification in accordance with ATEX Directive 94/9/EC.

CTB... series (Ex e) and (Ex i) stainless steel junction boxes

Ex e

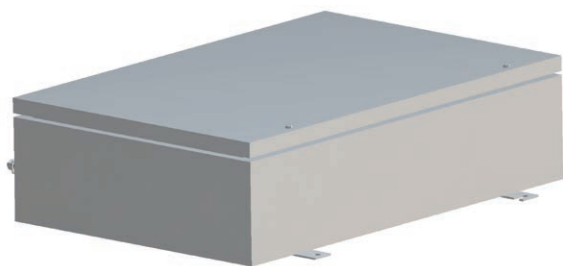

Zone 1,2,21,22.
Degree of protection IP66.
Stainless steel body and lid.
Acid/hydrocarbon-resistant gasket.
Stainless steel bolts and screws.
Impact protection IK10.

Ordering details

Standard stainless steel enclosure: **CTB765020**

Width/Depth/Height: **762/508/205mm**

Certification data for enclosures with terminals

Group II Category 2GD

Zone 1 - Zone 2 (Gas) Zone 21 - Zone 22 (Dust)

II 2GD Ex e IIC T.. Gb - Ex tb IIIC T.. Db IP66

II 2GD Ex ia IIC T.. Gb - Ex ia IIIC T.. Db IP66

II 2GD Ex e ia IIC T.. Gb - Ex tb ia IIIC T.. Db IP66

Ambient temperature: -40°C +55°C (+40°C)

Certification:

CESI 03 ATEX 333 (ATEX)

IEC Ex CES 13.0001 (IECEX)

Russian (GOST R)

Accessories

	CODE
2.5mm-thick stainless steel internal mounting plate:	B76-443
Terminal block mounting rails:	OBO2060/S
Breather and drain valve:	ECD-210S

Other:

Padlocking system

Internal anti-condensation coating

External epoxy coatings in different colour

Terminals

Clip for grouping cables in single bundle

M6 or M8 through earth connection

Plugs, cable glands, adapters, sealed bushings

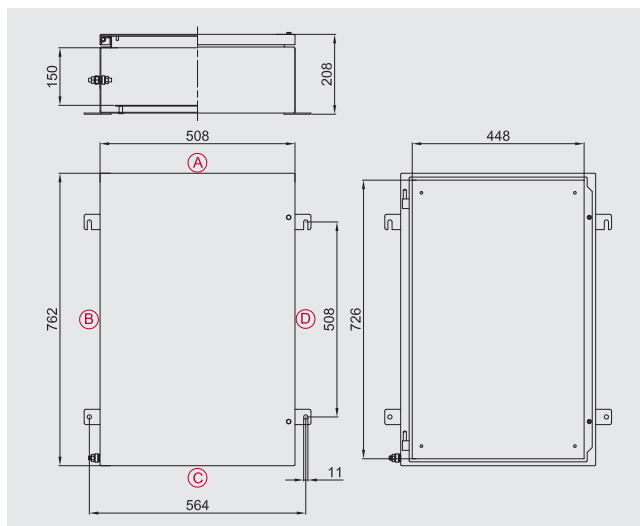

Ordering details for boxes with removable gland plates

Removable gland plate position coding

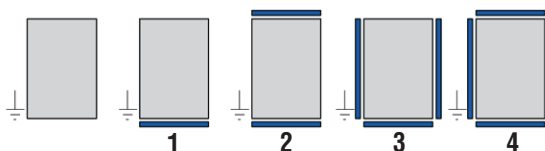

Ordering code examples

1) CTB503516S3

500x350x160 stainless steel box with 3 removable gland plates

2) CTB624520S4

620x450x205 stainless steel box with 4 removable gland plates

Max. number of terminals

X-SECT.	QTY.
2.5 mm ²	4x127
4 mm ²	4x106
6 mm ²	4x79
10 mm ²	3x63
16 mm ²	3x53
25 mm ²	3x39
70 mm ²	3x30
185 mm ²	17
300 mm ²	12



Eg. 2x22= 2 rows of 22 terminals (total 44 terminals). The maximum number of standard terminals refers to the mounting of CABUR and/or WEIDMULLER terminals.

The data in the table are given as a rough guide only based solely on the size of the enclosures and the space taken up by the terminals.

Number of cable glands

Standard enclosure			With removable gland plates		
Hole type	A/C	B/D	Hole type	A/C	B/D
M20	33	50	M20	33	42
M25	29	44	M25	16	22
M32	18	26	M32	14	22
M40	14	22	M40	10	16
M50	11	18	M50	5	8
M63	5	7	M63	4	5



Research conducted using Cortem's new REV and REVD series cable glands.

As required by the current standard, holes can be drilled by Cortem or by authorized partners who hold a production notification in accordance with ATEX Directive 94/9/EC.

CTB... series (Ex e) and (Ex i) stainless steel junction boxes

Ex e

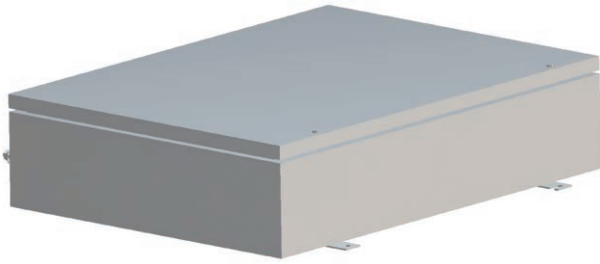

Zone 1,2,21,22.
Degree of protection IP66.
Stainless steel body and lid.
Acid/hydrocarbon-resistant gasket.
Stainless steel bolts and screws.
Impact protection IK10.

Ordering details

Standard stainless steel enclosure: **CTB866420**

Width/Depth/Height: **860/640/205mm**

Certification data for enclosures with terminals

Group II Category 2GD

Zone 1 - Zone 2 (Gas) Zone 21 - Zone 22 (Dust)

II 2GD Ex e IIC T.. Gb - Ex tb IIIC T.. Db IP66

II 2GD Ex ia IIC T.. Gb - Ex ia IIIC T.. Db IP66

II 2GD Ex e ia IIC T.. Gb - Ex tb ia IIIC T.. Db IP66

Ambient temperature: -40°C +55°C (+40°C)

Certification:

CESI 03 ATEX 333 (ATEX)

IEC Ex CES 13.0001 (IECEX)

Russian (GOST R)

Accessories

	CODE
2.5mm-thick stainless steel internal mounting plate:	B86-443
Terminal block mounting rails:	OBO2060/S
Breather and drain valve:	ECD-210S

Other:

Padlocking system

Internal anti-condensation coating

External epoxy coatings in different colour

Terminals

Clip for grouping cables in single bundle

M6 or M8 through earth connection

Plugs, cable glands, adapters, sealed bushings

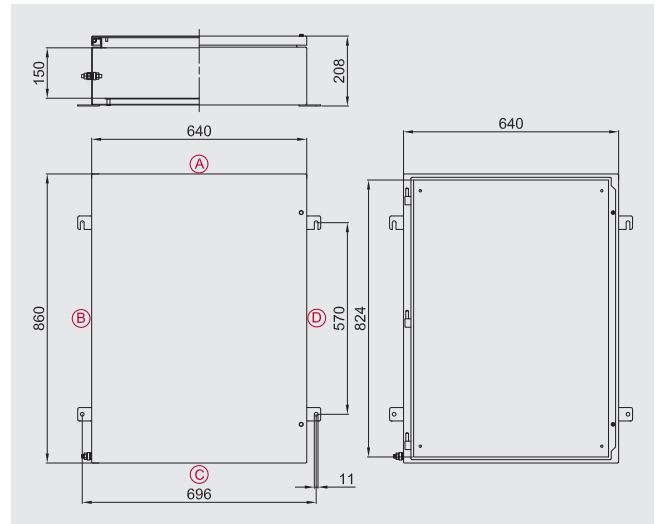

Ordering details for boxes with removable gland plates

Removable gland plate position coding

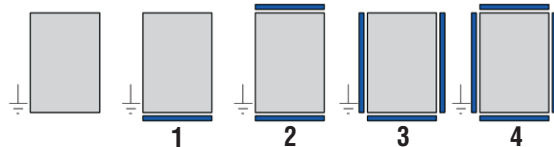

Ordering code examples

1) CTB503516S3

500x350x160 stainless steel box with 3 removable gland plates

2) CTB624520S4

620x450x205 stainless steel box with 4 removable gland plates

Max. number of terminals

X-SECT.	QTY.
2.5 mm ²	5x145
4 mm ²	5x121
6 mm ²	5x91
10 mm ²	5x72
16 mm ²	5x60
25 mm ²	4x45
70 mm ²	3x35
185 mm ²	20
300 mm ²	13



Eg. 2x22= 2 rows of 22 terminals (total 44 terminals). The maximum number of standard terminals refers to the mounting of CABUR and/or WEIDMULLER terminals.

The data in the table are given as a rough guide only based solely on the size of the enclosures and the space taken up by the terminals.

Number of cable glands

Standard enclosure			With removable gland plates		
Hole type	A/C	B/D	Hole type	A/C	B/D
M20	44	57	M20	44	48
M25	38	51	M25	36	36
M32	22	28	M32	20	20
M40	18	24	M40	16	16
M50	15	20	M50	8	8
M63	6	8	M63	6	6



Research conducted using Cortem's new REV and REVD series cable glands.

As required by the current standard, holes can be drilled by Cortem or by authorized partners who hold a production notification in accordance with ATEX Directive 94/9/EC.

CTB... series (Ex e) and (Ex i) stainless steel junction boxes

Ex e

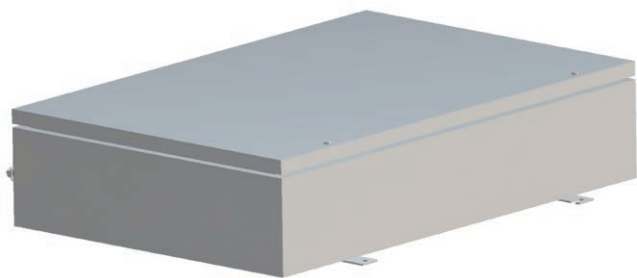

Zone 1,2,21,22.
 Degree of protection IP66.
 Stainless steel body and lid.
 Acid/hydrocarbon-resistant gasket.
 Stainless steel bolts and screws.
 Impact protection IK10.

Ordering details

Standard stainless steel enclosure:	CTB916120
Width/Depth/Height:	914/610/205mm

Certification data for enclosures with terminals

Group II Category 2GD
Zone 1 - Zone 2 (Gas) Zone 21 - Zone 22 (Dust)
II 2GD Ex e IIC T.. Gb - Ex tb IIIC T.. Db IP66
II 2GD Ex ia IIC T.. Gb - Ex ia IIIC T.. Db IP66
II 2GD Ex e ia IIC T.. Gb - Ex tb ia IIIC T.. Db IP66
Ambient temperature: -40°C +55°C (+40°C)

Certification:

CESI 03 ATEX 333 (ATEX)
 IEC Ex CES 13.0001 (IECEX)
 Russian (GOST R)

Accessories

	CODE
2.5mm-thick stainless steel internal mounting plate:	B91-443
Terminal block mounting rails:	OBO2060/S
Breather and drain valve:	ECD-210S

Other:

Padlocking system
 Internal anti-condensation coating
 External epoxy coatings in different colour
 Terminals
 Clip for grouping cables in single bundle
 M6 or M8 through earth connection
 Plugs, cable glands, adapters, sealed bushings

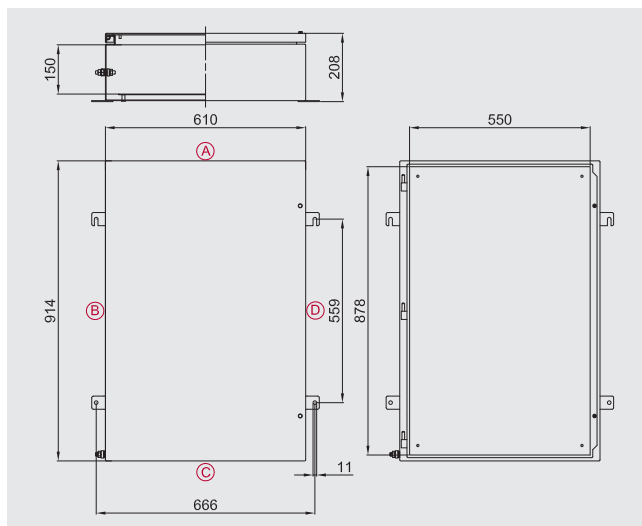

Ordering details for boxes with removable gland plates

Removable gland plate position coding

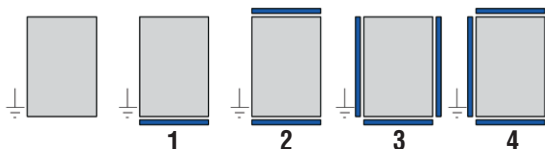

Ordering code examples

- CTB503516S3**
500x350x160 stainless steel box with 3 removable gland plates
- CTB624520S4**
620x450x205 stainless steel box with 4 removable gland plates

Max. number of terminals

X-SECT.	QTY.
2.5 mm ²	5x157
4 mm ²	5x131
6 mm ²	5x98
10 mm ²	5x78
16 mm ²	5x65
25 mm ²	4x49
70 mm ²	3x38
185 mm ²	21
300 mm ²	14



Eg. 2x22= 2 rows of 22 terminals (total 44 terminals). The maximum number of standard terminals refers to the mounting of CABUR and/or WEIDMULLER terminals.
 The data in the table are given as a rough guide only based solely on the size of the enclosures and the space taken up by the terminals.

Number of cable glands

Standard enclosure			With removable gland plates		
Hole type	A/C	B/D	Hole type	A/C	B/D
M20	41	60	M20	41	48
M25	35	53	M25	22	22
M32	20	30	M32	16	22
M40	18	26	M40	8	8
M50	14	22	M50	8	8
M63	6	9	M63	4	5



Research conducted using Cortem's new REV and REVD series cable glands.

As required by the current standard, holes can be drilled by Cortem or by authorized partners who hold a production notification in accordance with ATEX Directive 94/9/EC.

CTB... series (Ex e) and (Ex i) stainless steel junction boxes

Ex e

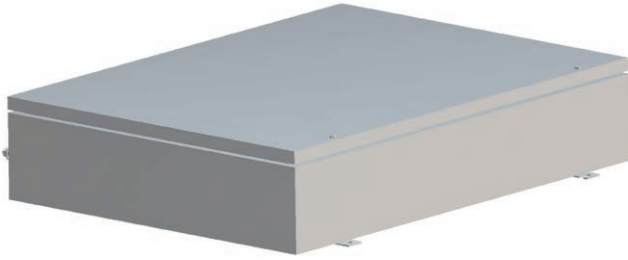

Zone 1,2,21,22.
Degree of protection IP66.
Stainless steel body and lid.
Acid/hydrocarbon-resistant gasket.
Stainless steel bolts and screws.
Impact protection IK10.

Ordering details

Standard stainless steel enclosure: **CTB987420**

Width/Depth/Height: **980/740/205mm**

Certification data for enclosures with terminals

Group II Category 2GD

Zone 1 - Zone 2 (Gas) Zone 21 - Zone 22 (Dust)

II 2GD Ex e IIC T.. Gb - Ex tb IIIC T.. Db IP66

II 2GD Ex ia IIC T.. Gb - Ex ia IIIC T.. Db IP66

II 2GD Ex e ia IIC T.. Gb - Ex tb ia IIIC T.. Db IP66

Ambient temperature: -40°C +55°C (+40°C)

Certification:

CESI 03 ATEX 333 (ATEX)

IEC Ex CES 13.0001 (IECEX)

Russian (GOST R)

Accessories

	CODE
2.5mm-thick stainless steel internal mounting plate:	B98-443
Terminal block mounting rails:	OBO2060/S
Breather and drain valve:	ECD-210S

Other:

Padlocking system

Internal anti-condensation coating

External epoxy coatings in different colour

Terminals

Clip for grouping cables in single bundle

M6 or M8 through earth connection

Plugs, cable glands, adapters, sealed bushings

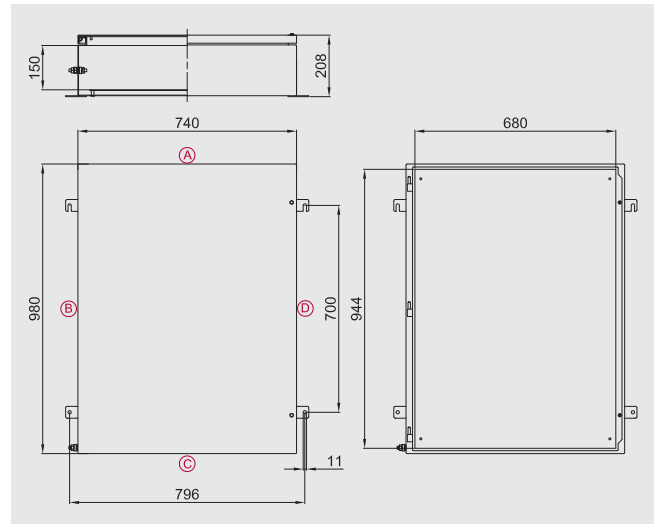

Ordering details for boxes with removable gland plates

Removable gland plate position coding

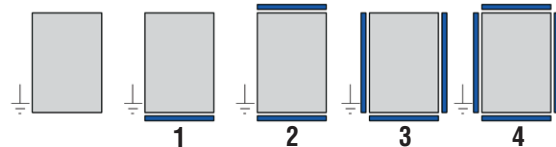

Ordering code examples

1) CTB503516S3

500x350x160 stainless steel box with 3 removable gland plates

2) CTB624520S4

620x450x205 stainless steel box with 4 removable gland plates

Max. number of terminals

X-SECT.	QTY.
2.5 mm ²	5x169
4 mm ²	5x141
6 mm ²	5x106
10 mm ²	5x84
16 mm ²	5x70
25 mm ²	4x52
70 mm ²	4x52
185 mm ²	23
300 mm ²	16



Eg. 2x22= 2 rows of 22 terminals (total 44 terminals). The maximum number of standard terminals refers to the mounting of CABUR and/or WEIDMULLER terminals.

The data in the table are given as a rough guide only based solely on the size of the enclosures and the space taken up by the terminals.

Number of cable glands

Standard enclosure			With removable gland plates		
Hole type	A/C	B/D	Hole type	A/C	B/D
M20	50	63	M20	44	58
M25	44	59	M25	36	48
M32	26	34	M32	20	28
M40	22	28	M40	16	20
M50	18	24	M50	8	10
M63	7	9	M63	6	8



Research conducted using Cortem's new REV and REVD series cable glands.

As required by the current standard, holes can be drilled by Cortem or by authorized partners who hold a production notification in accordance with ATEX Directive 94/9/EC.

