

# YFC

## Limit switch

- Group IIC
- Zone 1, 2, 21, 22
- Aluminium alloy
- Easy installation, wiring and maintenance
- Durable and safe over time

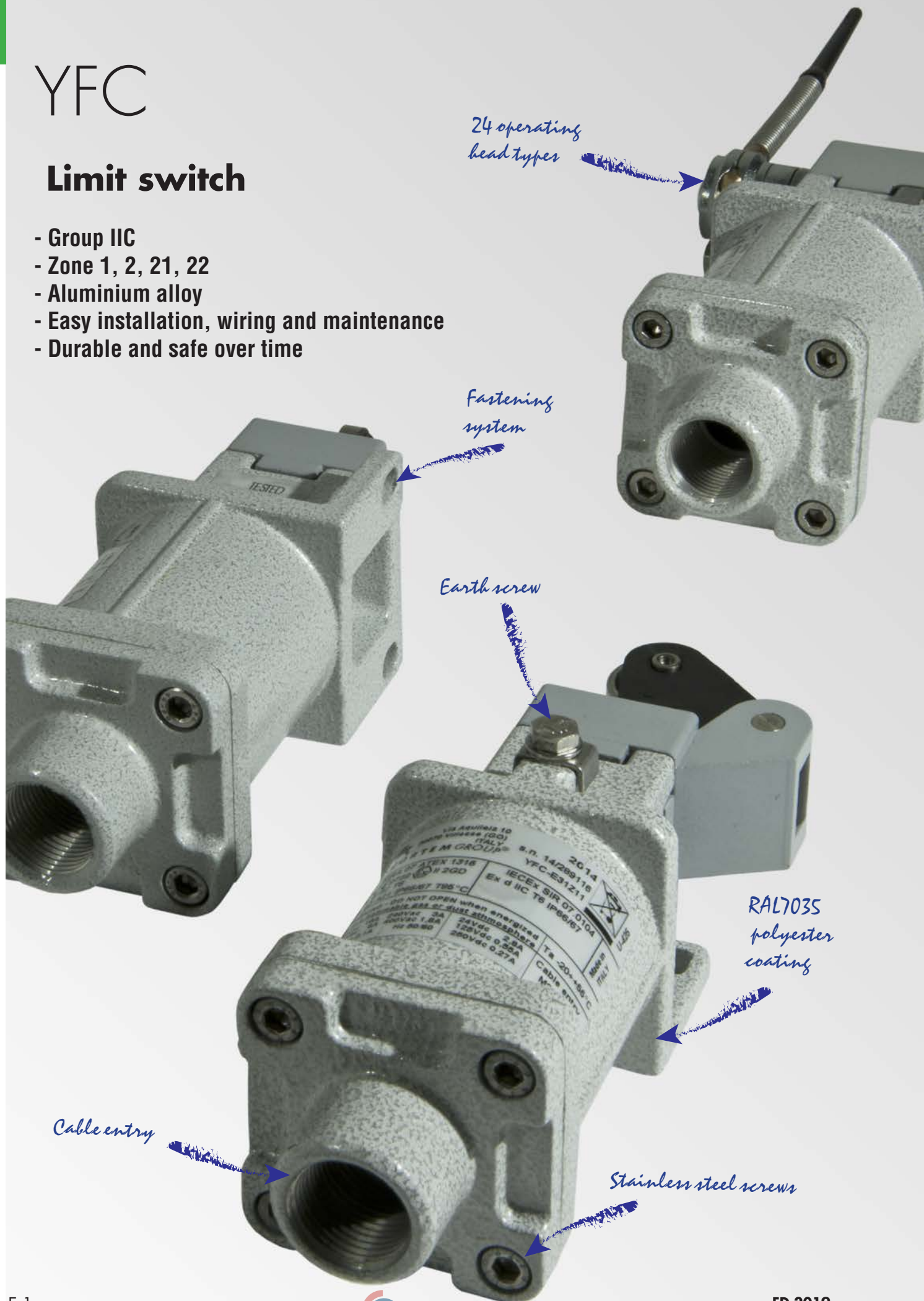

# YFC Series Limit switch

YFC Series explosion-proof limit switches feature an actuator linked mechanically to the contacts. The series includes both position switches and switches for safety applications. They are available in ten basic versions, depending on the type of actuator used, or sixty versions, if snap-action or slow-action contacts are considered.

Thanks to the combination of various types of actuators, bodies and contacts, YFC limit switches are ideal for a wide range of applications and for seamless system operation.

Being corrosion- and vibration-resistant, their mechanical and electrical components are able to withstand the extreme mechanical and thermal stresses they are continuously subjected to. Designed for installation in potentially explosive atmospheres, in the presence of combustible gases (hydrogen and acetylene), vapour, mist and powders, zones 1 and 21, 2 and 22, they are also used in watertight industrial and civil applications.

Cortem Group applies a tamper-evident holographic security label to its products, complete with a unique authentication numeric code, to combat the illegal sale of imitations and counterfeits, as well as guarantee the authenticity of its products. Failure to observe international standards creates serious risks for the environment and, above all, for the personnel who work with the systems on a daily basis.



## Sectors of application:



Petroleum refineries



Chemical and petrochemical facilities



Onshore facilities



Offshore facilities



Petroleum loading/unloading pontoons



Agribusiness facilities



Fuel storage facilities



100% produced by Cortem

## EMPTY ENCLOSURE CERTIFICATION DATA

|                                  |   |                          |   |  |
|----------------------------------|---|--------------------------|---|--|
| <b>Classification:</b>           | Group II  | Category 2GD             |   |  |
| <b>Installation:</b> EN 60079.14 | zone 1 - zone 2 (Gas)   | zone 21 - zone 22 (Dust) |   |  |
| <b>Marking:</b>                  | CE 0722 Ex II 2 GD Ex d IIC T6 Ex d tD A21 T85°C IP66/67  |                          |   |  |
| <b>Certificate:</b>              | ATEX  | <u>SIRA 07 ATEX 1316</u> |   |  |
|                                  | IEC Ex  | <u>IECEX SIR 07.0104</u> | For all IEC Ex and TR CU certification data, download the certificate from <a href="http://www.cortemgroup.com">www.cortemgroup.com</a> |  |
|                                  | TR CU   | <u>B.02204</u>           |   |  |
| <b>Standard:</b>                 | CENELEC EN 60079-0: 2006, EN 60079-1: 2004, EN 61241-0: 2006, EN 61241-1: 2004 and European Directive 2014/34/EU.<br>IEC 60079-0: 2004, IEC 60079-1: 2003, IEC 61241-0: 2004, IEC 61241-1: 2004<br>RoHS Directive 2002/95/EC. |                          |   |  |
| <b>Temperature class:</b>        | 85°C (T6)   |                          |   |  |
| <b>Ambient Temp.:</b>            | -20°C +55°C   |                          |   |  |
| <b>Degree of protection:</b>     | IP66/67   |                          |   |  |



A QR reader is required to access the information contained in the QRCode.

Centre the QR code in the frame of your Smartphone camera. Your Smartphone will open the corresponding address.



ATEX Certificate



IECEx Certificate



Use and maintenance instructions



### MECHANICAL FEATURES

|   |   |
|---|---|
| <b>Body:</b>  | Low copper content aluminium alloy, complete with wall fastening lugs                               |
| <b>Gaskets:</b>   | Acid, hydrocarbon and high temperature resistant silicone positioned between the body and the cover |
| <b>Certification label:</b>                                   | Adhesive affixed to external surface  |
| <b>Screws:</b>  | Stainless steel   |
| <b>Earth screw:</b>   | Internal and external stainless steel   |
| <b>Coating:</b>   | Polyester RAL 7035 (Light grey)   |
| <b>Entry points:</b>  | One entry point ISO M20x1.5   |
| <b>Mounting positions:</b>                                    | All positions   |
| <b>Consistency (measured following a million operations):</b> | 0.05 mm (at the point of closure)   |
| <b>Minimum control speed:</b>                                 | 0.06 m/s slow action<br>0.001 m/s snap action   |

#### Corrosion Resistance:

The STANDARD of the aluminium alloy used by Cortem has passed the tests required by standards EN60068-2-30 (hot-humid cycles) and EN60068-2-11 (salt fog test)

### ELECTRICAL FEATURES

|  |  |
|--|--|
| <b>Rated voltage:</b>                  | max. 500 Vac, 250 Vdc  |
| <b>Rated frequency:</b>                | max. 50/60 Hz  |
| <b>Rated current:</b>                  | 24 Vac - 50/60 Hz: 10 A<br>120 Vac - 50/60 Hz: 6 A<br>230 Vac - 50/60 Hz: 3.1<br>240 Vac - 50/60 Hz: 3.1 A<br>400 Vac - 50/60 Hz: 1.8 A<br>24 Vdc: 2.8 A<br>125 Vdc: 0.55 A<br>250 Vdc: 0.27 A |
| <b>Connecting cable cross-section:</b> | 0.75 ... 2.5 mm <sup>2</sup>   |

### ACCESSORIES UPON REQUEST / SPECIAL REQUESTS

Cable gland

# YFC Series Limit switch

## DIMENSIONAL DRAWING

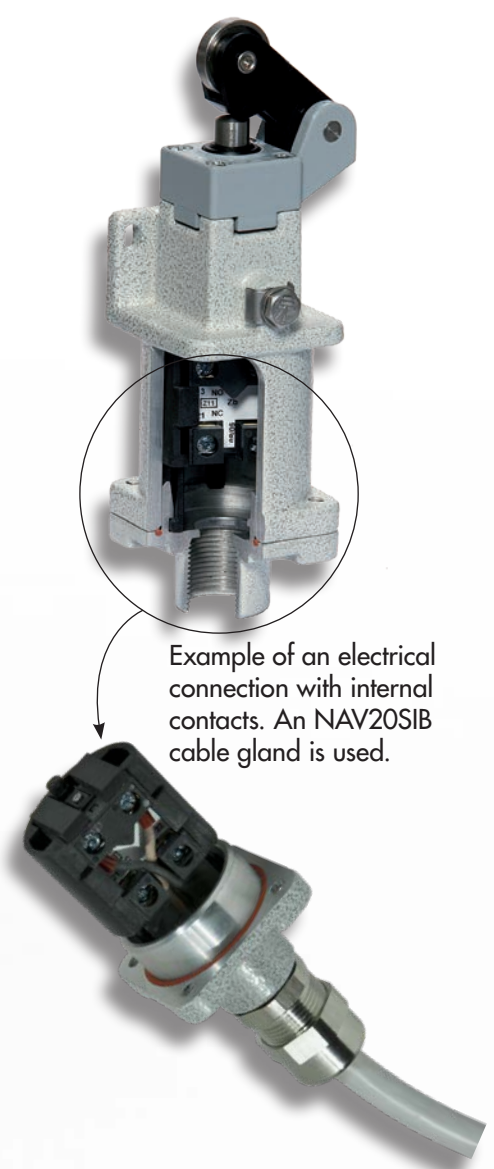
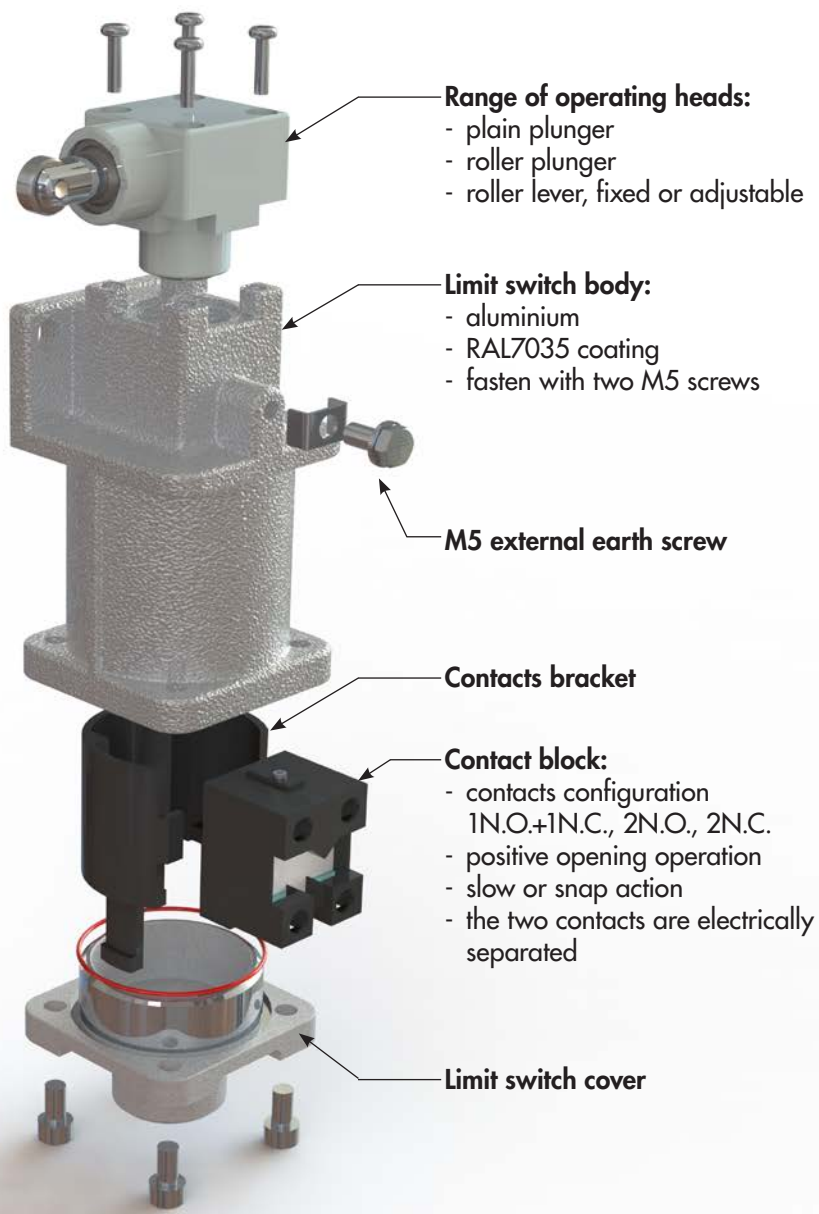
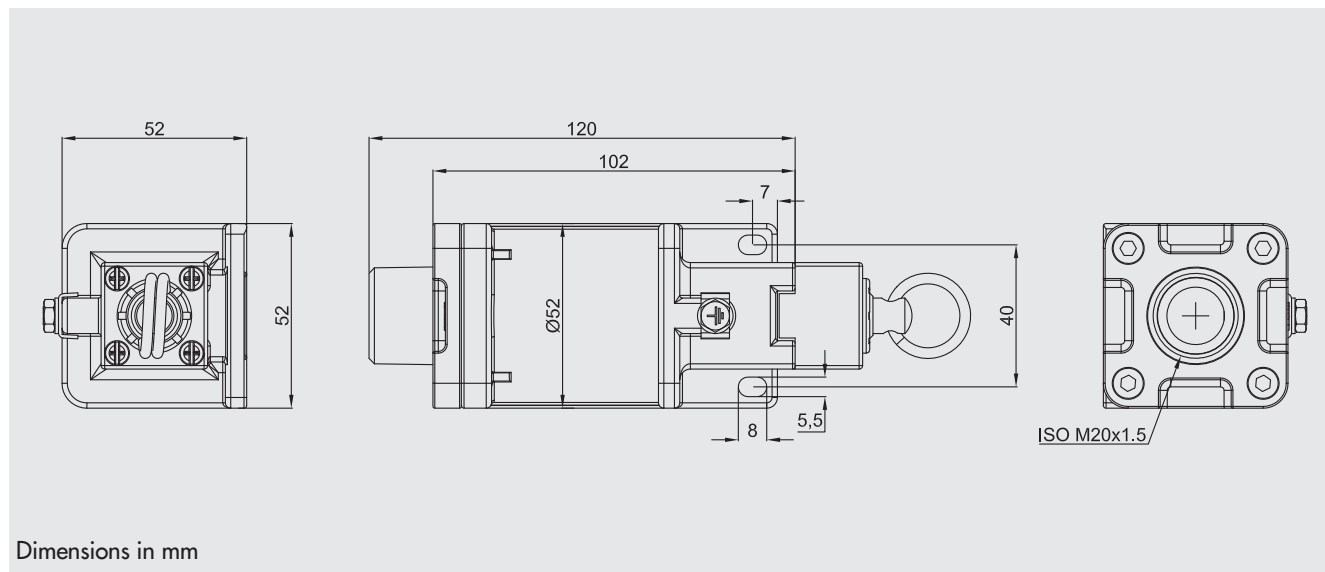

## TERMINOLOGY

### Positive opening operation



A control switch, with one or more break-contact elements, has a positive opening operation when the switch actuator (C) ensures the full opening of the contacts. For the part of travel that separates the contacts, there must be a positive zone with no resilient elements (e.g.: springs) between the moving contacts and the point where the actuator force is applied. The positive opening operation does not deal with N.O. contacts.

Control switches with positive opening operation may be provided with snap-action or slow-action contact elements. To use several contacts on the same control switch with positive opening operation, they must be electrically separated from each other; if not, only one contact may be used.

### Snap action

Snap action contacts are characterised by a release position that is distinct from the operating position. The opening (or closure) of snap-action contacts is independent of the switch actuator speed and contributes to regular electric performance, even for slow switch actuator speeds.

### Slow action

Slow-action contacts have a release position that is the same as the operating position. The switch actuator speed directly conditions the travel speed of contacts.

### Minimum actuation force / torque

The minimum amount of force/torque that is to be applied to the switch actuator to produce a change in contact position.

### Minimum force/torque to achieve positive opening operation

The minimum amount of force/torque that is to be applied to the switch actuator to ensure positive opening operation of the N.C. contact.

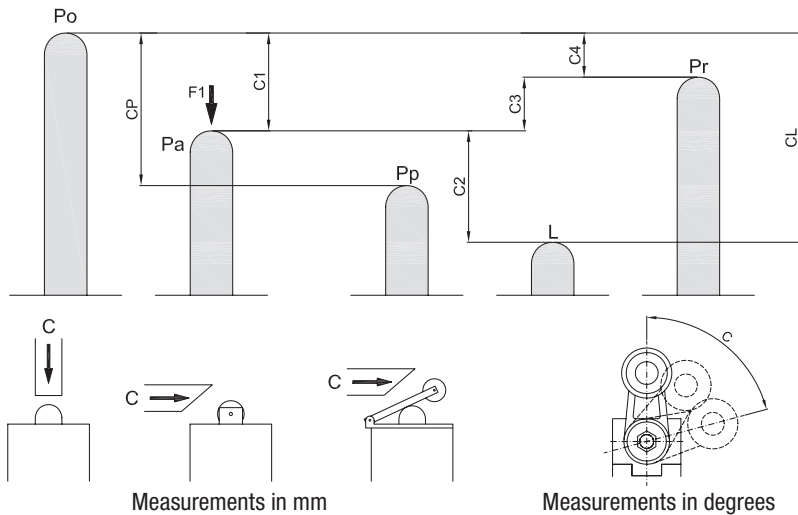

### Po Free position

Position of the switch actuator when no external force is exerted on it.

### Pa Operating position

Position of the switch actuator, under the effect of force F1, when the contacts leave their initial free position.

### Pp Positive opening position

Position of the switch actuator from which positive opening operation is ensured.

### L Max. travel position

Maximum acceptable travel position of the switch actuator under the effect of a force F1.

### Pr Release position

Position of the switch actuator when the contacts return to their initial free position.

### Travel for snap action contacts

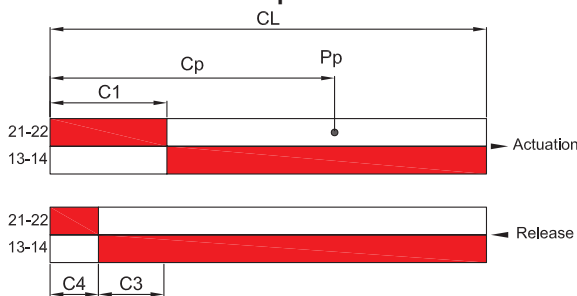

### Travel for non-overlapping slow-action contacts

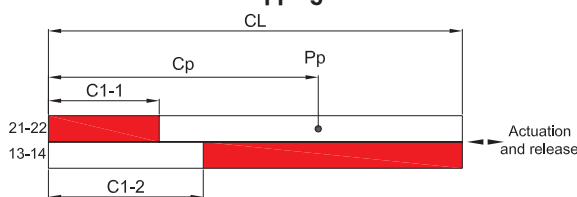

For slow-action contacts:

C3 = 0

C1-1 = pre-travel of contacts 21-22

C1-2 = pre-travel of contacts 13-14

### C1 Pre-travel

Distance between the free position Po and the operating position Pa.

### Cp Positive opening travel

Minimum travel of the switch actuator, from the free position Po, to ensure positive opening operation of the N.C. contacts.

### C2 Max. travel

Distance between the operating position Pa and the max. travel position L.

### CL Max. travel

Distance between the free position Po and the max. travel position L.

### C3 Differential travel (C1-C4)

Travel difference between Pa and Pr.

### C4 Release travel

Distance between Pr and Po.

# YFC Series Limit switch

## Sample order code

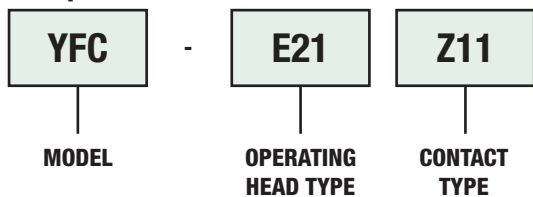











Limit switch with stainless steel lateral plain plunger and snap-action contact (1N.O. + 1N.C.)

## CODE SELECTION TABLE

| OPERATING HEAD MODEL   | E21<br>Stainless steel lateral plain plunger                                | E22<br>Stainless steel lateral plunger with Ø12 vertical roller              | E23<br>Stainless steel lateral plunger with Ø12 horizontal roller            |
|--|---|--|--|
| Compliance / (positive opening operation N.C. contacts)          | EN 50041  | EN 50041   | EN 50041   |
| Max. control speed [m/s]   | 0.5   | 0.5  | 0.5  |
| Minimum actuation force [N] or torque [Nm]                       | 30 / 50   | 30 / 50  | 30 / 50  |
| <b>CONTACT TYPE</b>  |   |  |  |
| <b>Z11</b><br>Snap-action contacts (1N.O.+1N.C.)                 | <br><b>YFC-E21Z11</b><br>0 2.0 3.2 4.8 6.0 mm<br>21-22 13-14<br>21-22 13-14 | <br><b>YFC-E22Z11</b><br>0 3.7 5.9 8.8 10.2 mm<br>21-22 13-14<br>21-22 13-14 | <br><b>YFC-E23Z11</b><br>0 3.7 5.9 8.8 10.2 mm<br>21-22 13-14<br>21-22 13-14 |
| <b>X11</b><br>Non-overlapping slow-action contacts (1N.O.+1N.C.) | <br><b>YFC-E21X11</b><br>0 2.3 3.9 6.0 mm<br>21-22 13-14<br>3.2             | <br><b>YFC-E22X11</b><br>0 4.6 7.5 10.2 mm<br>21-22 13-14<br>6.0             | <br><b>YFC-E23X11</b><br>0 4.6 7.5 10.2 mm<br>21-22 13-14<br>6.0             |
| <b>Y11</b><br>Non-overlapping slow-action contacts (1N.O.+1N.C.) | <br><b>YFC-E21Y11</b><br>0 3.6 5.2 6.0 mm<br>21-22 13-14<br>2.2             | <br><b>YFC-E22Y11</b><br>0 6.6 9.5 10.2 mm<br>21-22 13-14<br>4.3             | <br><b>YFC-E23Y11</b><br>0 6.6 9.5 10.2 mm<br>21-22 13-14<br>4.3             |
| <b>W02</b><br>Slow-action contacts (2N.C.)                       | <br><b>YFC-E21W02</b><br>0 2.2 3.8 6.0 mm<br>11-12 21-22                    | <br><b>YFC-E22W02</b><br>0 4.3 7.2 10.2 mm<br>11-12 21-22                    | <br><b>YFC-E23W02</b><br>0 4.3 7.2 10.2 mm<br>11-12 21-22                    |
| <b>W20</b><br>Slow-action contacts (2N.O.)                       | <br><b>YFC-E21W20</b><br>0 2.1 6.0 mm<br>13-14 23-24                        | <br><b>YFC-E22W20</b><br>0 4.1 10.2 mm<br>13-14 23-24                        | <br><b>YFC-E23W20</b><br>0 4.1 10.2 mm<br>13-14 23-24                        |
| <b>Z02</b><br>Slow-action contacts (2N.O.)                       | <br><b>YFC-E21Z02</b><br>0 2.0 3.1 4.7 6.0 mm<br>11-12 21-22<br>11-12 21-22 | <br><b>YFC-E22Z02</b><br>0 3.7 5.7 8.6 10.2 mm<br>11-12 21-22<br>11-12 21-22 | <br><b>YFC-E23Z02</b><br>0 3.7 5.7 8.6 10.2 mm<br>11-12 21-22<br>11-12 21-22 |
| <b>DIMENSIONS (mm)</b>   |   |  |  |

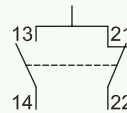
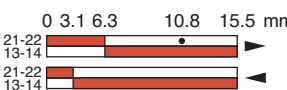
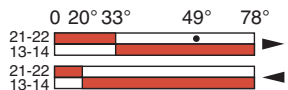
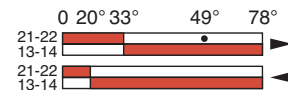
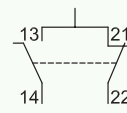
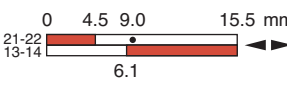
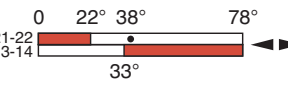
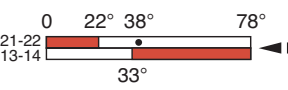
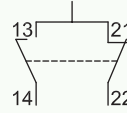
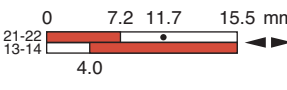
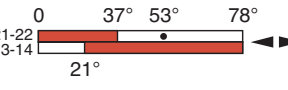
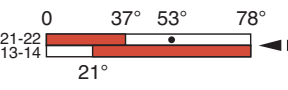
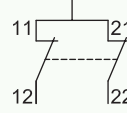

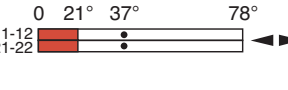
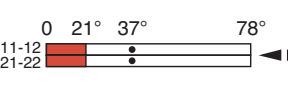
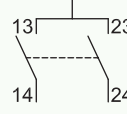

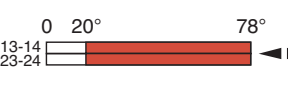
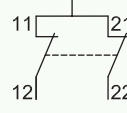
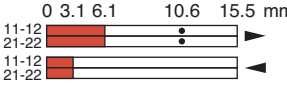
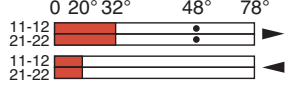
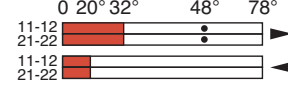
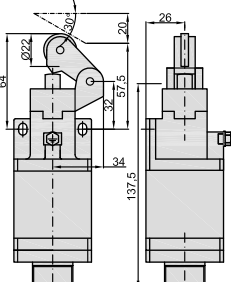
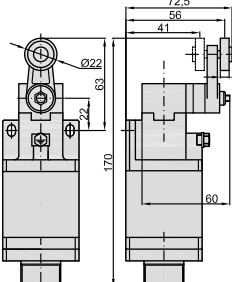
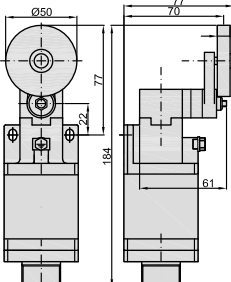





# YFC Series Limit switch

## CODE SELECTION TABLE

| <b>OPERATING HEAD MODEL</b>  | <b>E3.</b><br>One way lever Ø22<br><b>E31:</b> nylon roller<br><b>E32:</b> stainless steel roller<br><b>E33:</b> steel bearing  | <b>E4..</b><br>Lever with Ø22 roller<br><b>E41:</b> nylon roller<br><b>E42:</b> stainless steel roller<br><b>E43:</b> steel bearing  | <b>E44</b><br>Lever with Ø50 rubber roller      |
|--|--|---|--|
| Compliance / (positive opening operation N.C. contacts)  | EN 50041    | EN 50041   | EN 50041                                        |
| Max. control speed [m/s]   | 1.5  | 1.5   | 1.5  |
| Minimum actuation force [N] or torque [Nm]   | 12 / 40  | 0.15 / 0.30   | 0.15 / 0.30  |
| <b>CONTACT TYPE</b>  |  |   |  |
| <b>Z11</b><br>Snap-action contacts (1N.O.+1N.C.)                    | <b>YFC-E3.Z11</b><br>0 3.1 6.3 10.8 15.5 mm<br>   | <b>YFC-E4.Z11</b><br>0 20° 33° 49° 78°<br>  | <b>YFC-E4.Z11</b><br>0 20° 33° 49° 78°<br>      |
| <b>X11</b><br>Non-overlapping slow-action contacts (1N.O.+1N.C.)   | <b>YFC-E3.X11</b><br>0 4.5 9.0 15.5 mm<br>6.1<br>  | <b>YFC-E4.X11</b><br>0 22° 38° 78°<br>33°<br>  | <b>YFC-E4.X11</b><br>0 22° 38° 78°<br>33°<br>  |
| <b>Y11</b><br>Non-overlapping slow-action contacts (1N.O.+1N.C.)  | <b>YFC-E3.Y11</b><br>0 7.2 11.7 15.5 mm<br>4.0<br>  | <b>YFC-E4.Y11</b><br>0 37° 53° 78°<br>21°<br>   | <b>YFC-E4.Y11</b><br>0 37° 53° 78°<br>21°<br> |
| <b>W02</b><br>Slow-action contacts (2N.C.)                        | <b>YFC-E3.W02</b><br>0 4.0 9.5 15.5 mm<br>  | <b>YFC-E4.W02</b><br>0 21° 37° 78°<br>  | <b>YFC-E4.W02</b><br>0 21° 37° 78°<br>        |
| <b>W20</b><br>Slow-action contacts (2N.O.)                        | <b>YFC-E3.W20</b><br>0 3.6 15.5 mm<br>  | <b>YFC-E22W20</b><br>0 20° 78°<br>  | <b>YFC-E4.W20</b><br>0 20° 78°<br>            |
| <b>Z02</b><br>Slow-action contacts (2N.O.)                        | <b>YFC-E3.Z02</b><br>0 3.1 6.1 10.6 15.5 mm<br>   | <b>YFC-E4.Z02</b><br>0 20° 32° 48° 78°<br>  | <b>YFC-E4.Z02</b><br>0 20° 32° 48° 78°<br>    |
| <b>DIMENSIONS (mm)</b>   |   |   |   |

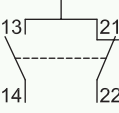
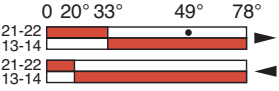
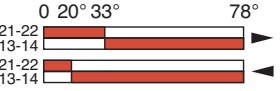
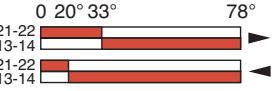
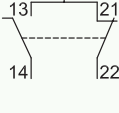
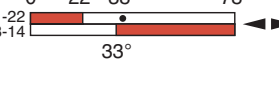
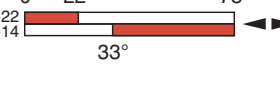
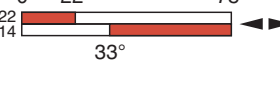
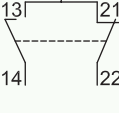
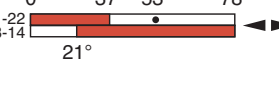
# YFC Series Limit switch

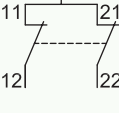

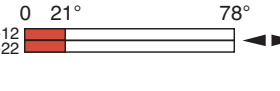
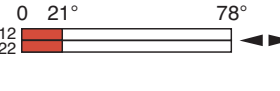
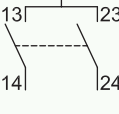
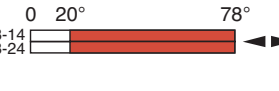
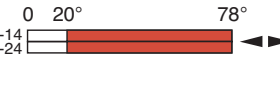
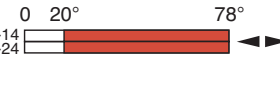
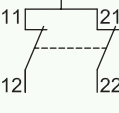
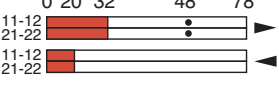
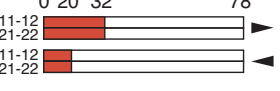
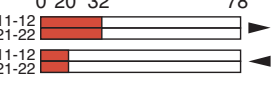
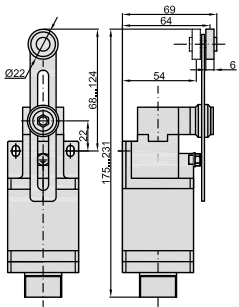
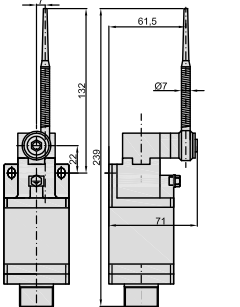
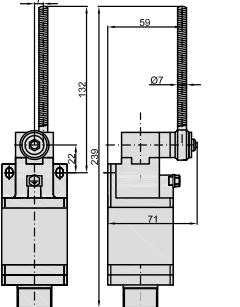







## CODE SELECTION TABLE

| <b>OPERATING HEAD MODEL</b>  | <b>E5.</b><br>One way lever Ø22<br><b>E51:</b> nylon roller<br><b>E52:</b> stainless steel roller<br><b>E53:</b> steel bearing  | <b>E61</b><br>Nylon actuator with a stainless steel spring               | <b>E62</b><br>Stainless steel spring actuator                             |
|--|--|---|--|
| Compliance / (positive opening operation N.C. contacts)  | EN 50041    | EN 50041   | EN 50041    |
| Max. control speed [m/s]   | 1.5  | 1.5   | 1.5  |
| Minimum actuation force [N] or torque [Nm]   | 0.15 / 0.30  | 0.15 / -  | 0.15 / -   |
| <b>CONTACT TYPE</b>  |  |   |  |
| <b>Z11</b><br>Snap-action contacts (1N.O.+1N.C.)                    | <b>YFC-E5.Z11</b><br>0 20° 33° 49° 78°<br>  | <b>YFC-E61Z11</b><br>0 20° 33° 78°<br>                                    | <b>YFC-E62Z11</b><br>0 20° 33° 78°<br>                                    |
| <b>X11</b><br>Non-overlapping slow-action contacts (1N.O.+1N.C.)   | <b>YFC-E5.X11</b><br>0 22° 38° 78°<br>21-22<br>13-14<br>33°    | <b>YFC-E61X11</b><br>0 22° 78°<br>21-22<br>13-14<br>33°                  | <b>YFC-E62X11</b><br>0 22° 78°<br>21-22<br>13-14<br>33°                  |
| <b>Y11</b><br>Non-overlapping slow-action contacts (1N.O.+1N.C.)  | <b>YFC-E5.Y11</b><br>0 37° 53° 78°<br>21-22<br>13-14<br>21°   | <b>YFC-E61Y11</b><br>0 37° 78°<br>21-22<br>13-14<br>21°                 | <b>YFC-E62Y11</b><br>0 37° 78°<br>21-22<br>13-14<br>21°                 |
| <b>W02</b><br>Slow-action contacts (2N.C.)                        | <b>YFC-E5.W02</b><br>0 21° 37° 78°<br>11-12<br>21-22    | <b>YFC-E61W02</b><br>0 21° 78°<br>11-12<br>21-22                        | <b>YFC-E62W02</b><br>0 21° 78°<br>11-12<br>21-22                        |
| <b>W20</b><br>Slow-action contacts (2N.O.)                        | <b>YFC-E5.W20</b><br>0 20° 78°<br>13-14<br>23-24    | <b>YFC-E61W20</b><br>0 20° 78°<br>13-14<br>23-24                        | <b>YFC-E62W20</b><br>0 20° 78°<br>13-14<br>23-24                        |
| <b>Z02</b><br>Slow-action contacts (2N.O.)                        | <b>YFC-E5.Z02</b><br>0 20° 32° 48° 78°<br>11-12<br>21-22<br>11-12<br>21-22    | <b>YFC-E61Z02</b><br>0 20° 32° 78°<br>11-12<br>21-22<br>11-12<br>21-22  | <b>YFC-E62Z02</b><br>0 20° 32° 78°<br>11-12<br>21-22<br>11-12<br>21-22  |
| <b>DIMENSIONS (mm)</b>   |   |   |   |



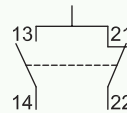
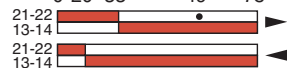
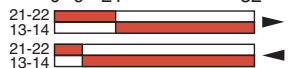
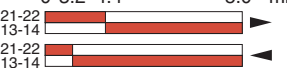
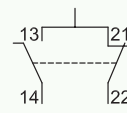
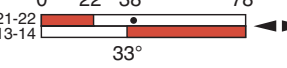
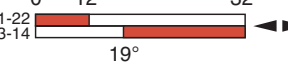
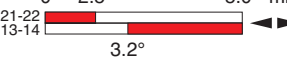
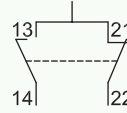
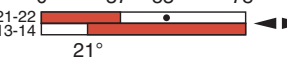
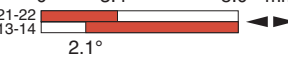
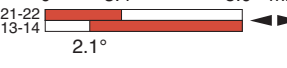
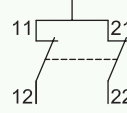
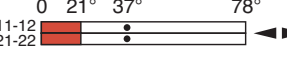
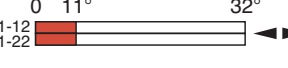
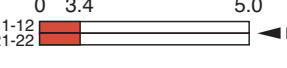
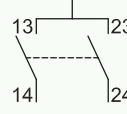

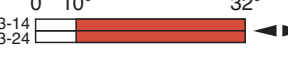

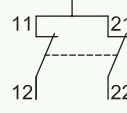
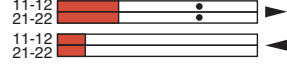
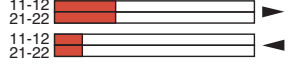
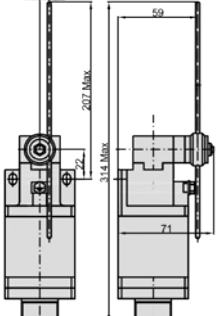
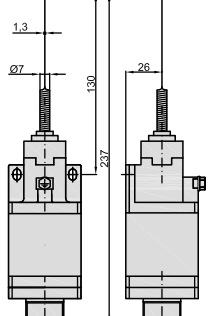
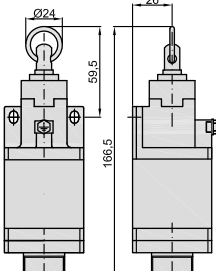











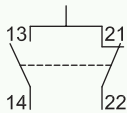
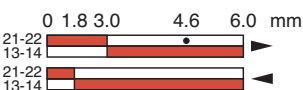
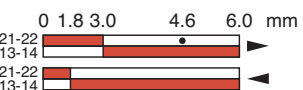
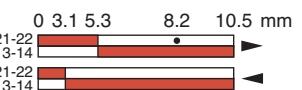
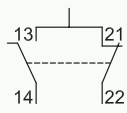
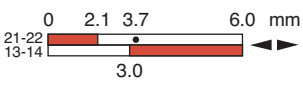
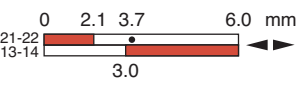
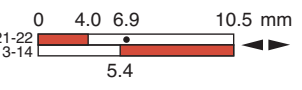
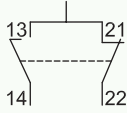
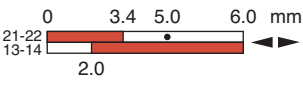
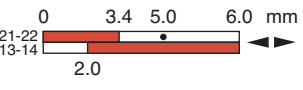
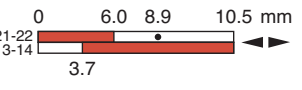
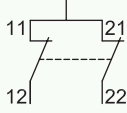

# YFC Series Limit switch

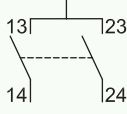
## CODE SELECTION TABLE

| <b>OPERATING HEAD MODEL</b>   | <b>E7..</b><br>Adjustable rod lever<br><b>E71:</b> stainless steel rod Ø3<br><b>E72:</b> nylon rod Ø6<br><b>E73:</b> fibreglass rod Ø3<br><b>E75:</b> metal rod 3x3<br> | <b>E91</b><br>Multi-directional stainless steel spring actuator<br> | <b>E99</b><br>Pull action with ring<br>                 |
|---|--|--|--|
| Compliance / (positive opening operation N.C. contacts)   | EN 50041    | EN 50041    | EN 50041    |
| Max. control speed [m/s]  | 1.5  | 1  | 0.5  |
| Minimum actuation force [N] or torque [Nm]  | 0.15 / 0.30  | 0.18 / -   | 25 / -   |
| <b>CONTACT TYPE</b>   |  |  |  |
| <b>Z11</b><br>Snap-action contacts (1N.O.+1N.C.)<br>                   | <b>YFC-E7.Z11</b><br>0 20° 33° 49° 78°<br>  | <b>YFC-E91Z11</b><br>0 9° 21° 32°<br>                                | <b>YFC-E99Z11</b><br>0 3.2° 4.4° 5.0° mm<br>            |
| <b>X11</b><br>Non-overlapping slow-action contacts (1N.O.+1N.C.)<br>  | <b>YFC-E7.X11</b><br>0 22° 38° 78°<br>21-22 33°<br>  | <b>YFC-E91X11</b><br>0 12° 32°<br>21-22 19°<br>                     | <b>YFC-E99X11</b><br>0 2.5° 5.0° mm<br>21-22 3.2°<br>  |
| <b>Y11</b><br>Non-overlapping slow-action contacts (1N.O.+1N.C.)<br> | <b>YFC-E7.Y11</b><br>0 37° 53° 78°<br>21-22 21°<br>   | <b>YFC-E91Y11</b><br>0 3.4° 5.0° mm<br>21-22 2.1°<br>              | <b>YFC-E99Y11</b><br>0 3.4° 5.0° mm<br>21-22 2.1°<br> |
| <b>W02</b><br>Slow-action contacts (2N.C.)<br>                       | <b>YFC-E7.W02</b><br>0 21° 37° 78°<br>11-12 21-22<br>   | <b>YFC-E91W02</b><br>0 11° 32°<br>11-12 21-22<br>                  | <b>YFC-E99W02</b><br>0 3.4 5.0<br>11-12 21-22<br>     |
| <b>W20</b><br>Slow-action contacts (2N.O.)<br>                       | <b>YFC-E7.W20</b><br>0 20° 78°<br>13-14 23-24<br>   | <b>YFC-E91W20</b><br>0 10° 32°<br>13-14 23-24<br>                  | <b>YFC-E99W20</b><br>0 3.6 5.0<br>13-14 23-24<br>     |
| <b>Z02</b><br>Slow-action contacts (2N.O.)<br>                       | <b>YFC-E7.Z02</b><br>0 20° 32° 48° 78°<br>11-12 21-22<br>   | <b>YFC-E91Z02</b><br>0 9° 20° 32°<br>11-12 21-22<br>               |  |
| <b>DIMENSIONS (mm)</b>  |   |    |   |

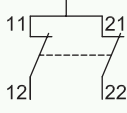
# YFC Series Limit switch

## CODE SELECTION TABLE

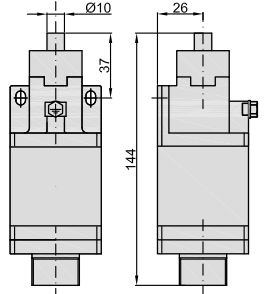
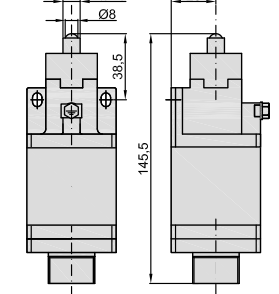
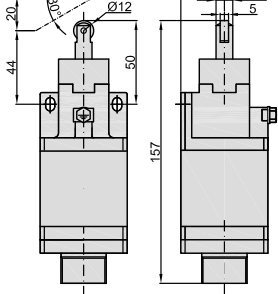
| <b>OPERATING HEAD MODEL</b>   | <b>E11</b><br>Stainless steel plain plunger<br> | <b>E12</b><br>Stainless steel ball plunger<br> | <b>E13</b><br>Stainless steel roller plunger Ø12<br> |
|---|--|--|---|
| Compliance / (positive opening operation N.C. contacts)   | EN 50041                                        | EN 50041                                      | EN 50041   |
| Max. control speed [m/s]  | 0.5  | 0.5  | 0.5   |
| Minimum actuation force or torque   | 30 / 45  | 30 / 45  | 22 / 40   |
| <b>CONTACT TYPE</b>   |  |  |   |
| <b>Z11</b><br>Snap-action contacts (1N.O.+1N.C.)<br>                   | <b>YFC-E11Z11</b><br>                           | <b>YFC-E12Z11</b><br>                          | <b>YFC-E13Z11</b><br>                                |
| <b>X11</b><br>Non-overlapping slow-action contacts (1N.O.+1N.C.)<br>  | <b>YFC-E11X11</b><br>                          | <b>YFC-E61X11</b><br>                         | <b>YFC-E13X11</b><br>                               |
| <b>Y11</b><br>Non-overlapping slow-action contacts (1N.O.+1N.C.)<br> | <b>YFC-E11Y11</b><br>                         | <b>YFC-E61Y11</b><br>                        | <b>YFC-E13Y11</b><br>                              |
| <b>W02</b><br>Slow-action contacts (2N.C.)<br>                       | <b>YFC-E11W02</b><br>                         | <b>YFC-E61W02</b><br>                        | <b>YFC-E13W02</b><br>                              |
| <b>W20</b><br>Slow-action contacts (2N.O.)<br>                       | <b>YFC-E11W20</b><br>                         | <b>YFC-E61W20</b><br>                        | <b>YFC-E13W20</b><br>                              |
| <b>Z02</b><br>Slow-action contacts (2N.O.)<br>                       | <b>YFC-E11Z02</b><br>                         | <b>YFC-E61Z02</b><br>                        | <b>YFC-E13Z02</b><br>                              |
| <b>DIMENSIONS (mm)</b>  |   |    |    |